

TextiPad
*Implementation and
Evaluation of a Wearable
Textile Touchpad*

Master's Thesis at the
Media Computing Group
Prof. Dr. Jan Borchers
Computer Science Department
RWTH Aachen University



by
Stefan Ivanov

Thesis advisor:
Prof. Dr. Jan Borchers

Second examiner:
Prof. Dr. -Ing. Stefan Kowalewski

Registration date: June 06th, 2012
Submission date: Sept 25th, 2012

I hereby declare that I have created this work completely on my own and used no other sources or tools than the ones listed, and that I have marked any citations accordingly.

Hiermit versichere ich, dass ich die vorliegende Arbeit selbständig verfasst und keine anderen als die angegebenen Quellen und Hilfsmittel benutzt sowie Zitate kenntlich gemacht habe.

Aachen, September 2012
STEFAN IVANOV

Contents

Abstract	xvii
Acknowledgements	xix
Conventions	xxi
1 Introduction	1
2 Related work	5
2.1 Discrete input prototypes	5
2.2 Continuous input prototypes	7
2.3 Gesture articulation on garments	9
3 Prototype requirements	13
3.1 Requirements related to physical characteristics	14
3.2 Designing for eyes-free interaction	16
3.3 Guidelines	20
3.4 Materials	20

4	Design	23
4.1	Hardware design	23
4.1.1	Architecture	24
4.1.2	Initial experimentation	26
4.1.3	First iteration of the hardware	28
4.1.4	Second iteration of the hardware	29
4.1.5	Third iteration of the hardware	31
4.1.6	Sensor characteristics	32
4.2	Software design	34
4.2.1	Design of the microcontroller software	34
4.2.2	Design of an application for drawing input paths	39
4.2.3	Target acquisition application design	40
4.2.4	Design of gestural menu navigation application	41
5	Implementation	45
5.1	<i>TextiPad</i>	45
5.2	<i>GestiPants</i>	48
5.3	Gesture identification and recognition	50
6	Evaluation	53
6.1	Proof of functionality study	53
6.2	Target acquisition study	57

6.2.1	Study design	58
6.2.2	Setup and procedure	59
6.2.3	Participants	60
6.2.4	Results and analysis	60
6.3	Study for menu navigation through gestures	66
6.3.1	Study design	66
6.3.2	Setup and procedure	69
6.3.3	Participants	71
6.3.4	Results and analysis	72
7	Post-study optimization	81
8	Summary and future work	85
8.1	Summary and contributions	85
8.2	Future work	87
A	Templates used in evaluation	91
B	Detailed results from user studies	99
C	Optimization results	119
	Bibliography	121
	Index	129

List of Figures

4.1	Initial layered architecture.	26
4.2	Comparison of different mesh materials	27
4.3	Improved layered architecture.	30
4.4	Approximate range of sample points.	31
4.5	Final layered architecture.	32
4.6	Prototype with respect to the design space for input devices [Card et al., 1990].	33
4.7	Measurement algorithm executed in the be- ginning of each run loop.	35
4.8	Scheme for calibrating the sensor.	36
4.9	Screenshot of application visualizing touch paths.	39
4.10	Screenshot of application for target acqui- sition - variant of "Wack-a-mole" game.	40
4.11	Articulating a gesture from knee towards the waist.	43
4.12	Screenshot of application for gestural menu navigation.	44

5.1	Steps for creating <i>TextiPad</i>	46
5.2	Finished prototype ready for evaluation. . . .	47
5.3	Steps for embedding a sensor in <i>GestiPants</i> . .	48
5.4	<i>GestiPants</i> - pair of jeans with a sensor embedded in each leg.	49
5.5	<i>GestiPants</i> worn.	50
6.1	Garment wrapped around participant's thigh for articulating with baking flour. . . .	54
6.2	Unwanted contact paths.	55
6.3	Registered gestural paths.	56
6.4	Setup for target acquisition study.	59
6.5	Experience with touch-sensing technology for the target acquisition study.	61
6.6	Combined placement and orientation map. . .	62
6.7	Subjective perception of the sensor for the target acquisition study for questions 1-3. . .	65
6.8	Subjective perception of the sensor for the target acquisition study for questions 4-6. . .	65
6.9	Scheme of the setup for the menu navigation study.	69
6.10	Photos taken of the setup for the menu navigation study.	70
6.11	Experience with touch-sensing technology for the menu navigation study.	72
6.12	Image maps for the two vertical gestures for the menu navigation study.	73

6.13	Image maps for the two horizontal gestures for the menu navigation study.	74
6.14	Learning curves for all treatments for <i>Gesti-Pants</i>	77
6.15	Subjective perception of the embedded sensor for the menu navigation study for questions 1-3.	78
6.16	Subjective perception of the embedded sensor for the menu navigation study for questions 4-6.	78
7.1	Merging gestures that are part of the same articulation.	82
7.2	Enhancement of recognition rate by merging relevant gestures.	83
8.1	Two approaches for interacting with a convex curved surface.	88
8.2	Variance in the orientation of gestures articulated on the thigh.	88
A.1	Informed consent form provided to participants prior to the start of the proof of functionality study	92
A.2	Questionnaire filled by participants in the end of the proof of functionality study	93
A.3	Informed consent form provided to participants prior to the start of the target acquisition study	94
A.4	Handedness questionnaire according to the Edinburgh inventory	95
A.5	Sets of tasks used in the menu navigation study	96

A.6	Informed consent form provided to participants prior to the start of the gestural menu navigation study	97
A.7	Questionnaire filled by participants in the end of the gestural menu navigation study	98
B.1	Results from study on size and shape of the sensing area	100
B.2	Results from proof of functionality study	101
B.3	First questionnaire responses	102
B.4	Proof of functionality questionnaire graphs	103
B.5	Proof of functionality participants' experience graphs	104
B.6	Table with laterality indices for participants' handedness for the target acquisition study	105
B.7	Summary of results extracted from the log files for target acquisition study	106
B.8	Placement map for precisely locating sensor on the thigh	107
B.9	Orientation map for precisely aligning the sensor with respect to the thigh	107
B.10	Detailed statistical results about task completion time for target acquisition study	108
B.11	Detailed statistical results about initial pointing error for target acquisition study	109
B.12	Table with laterality indices for participants' handedness for the menu navigation study	110
B.13	Summary of results extracted from the log files for menu navigation study	111

B.14	Detailed statistical results about average gesture duration for menu navigation study . . .	112
B.15	Detailed statistical results about average recognized gesture duration for menu navigation study	113
B.16	Detailed statistical results about average not recognized gesture duration for menu navigation study	114
B.17	Detailed statistical results about recognition rate for menu navigation study	115
B.18	Detailed statistical results about the amount of recognized gestures for menu navigation study	116
B.19	Detailed statistical results about the amount of identified gestures for menu navigation study	117
B.20	Second questionnaire replies	118
C.1	Optimization results	120

List of Tables

3.1	Wearables requirements related to physical characteristics	17
4.1	Items used for the menu	42

Abstract

TextiPad is a smart-textile prototype, seamlessly embedded into everyday clothing. It is a thin, flexible, and relatively cheap touch-sensing surface that allows the control of software applications. *TextiPad* has a multi-layer architecture, where three of the layers serve as the basis for sensing touches. It is a resistive touch sensor, therefore only a single location of touch can be identified. Its continuous monitoring over time allows for extracting gestures, which can be forwarded to a recognizer, comparing them to a predefined set. Due to the affordances of smart textiles and wearable technology, it is certain that such a device is to be used in a mobile context and for this reason we designed it to be wearable. Furthermore, all design and implementation steps depicted in this thesis, take the surrounding environment for mobile usage in account. This work describes two prototypes and their evaluation: *TextiPad*, which represents the bare sensing element, and *GestiPants*, which is a pair of trousers with a sensor embedded in each leg. The evaluation consists of a proof of functionality study, conducted with a few users, as well as two formal assessments, completed by large groups of participants. The first one served to confirm the proper functioning of the hardware and software, while the other two aimed at gathering usability data for different usage scenarios. Aside from having a working and usable product, among our objectives were reliability, robustness and low-cost of the sensor that potentially encourage adoption by the market.

Acknowledgements

This thesis would not have been possible without the support from a number of people and organizations.

First I would like to thank the Media Computing Group at RWTH-Aachen and all my friends and colleagues there for the support and constant feedback on my work. I would also like to thank Mr. Carsten Classe from AMOHR Technische Textilien GmbH for the provided conductive tape samples for my final prototype.

I would like to thank Prof. Jan Borchers and Florian Heller for their supervision and guidance. I would like to thank Chatchavan Wacharamanotham for his remarks on the design of my user studies and help in analyzing the data collected, and to Dominik Poppe for helping me to get started with the sensor construction.

In the end, I would like to thank my family and friends for the moral support and their belief in me and my work and to all the participants in my user studies for their priceless feedback.

Conventions

Throughout this thesis we use the following conventions.

Text conventions

Definitions of technical terms or short excursus are set off in colored boxes.

EXCURSUS:

Excursus are detailed discussions of a particular point in a book, usually in an appendix, or digressions in a written text.

Definition:
Excursus

Source code and implementation symbols are written in typewriter-style text.

```
myClass
```

The entire thesis is written in American English.

Download links are set off in colored boxes.

[Download file: File name^a](#)

^ahttp://media.informatik.rwth-aachen.de/~ACCOUNT/thesis/folder/file_name.file

Chapter 1

Introduction

The miniaturization of digital technology in the past few decades afforded the development of lightweight, powerful mobile devices that are presently very widespread. However, research about mobile systems, and wearable computing in particular, dates back a few decades with works done in the early 80's by pioneers like Mann [1997]. His initial prototypes were hardly wearable but they were the first that one can refer to as smart clothing.

SMART CLOTHING:

Garment with embedded electrical components that enhance its features

Definition:
Smart Clothing

Many years have passed since then, and when one tracks the vast number of iterations made on his prototype, he can see how his most recent work is wearable and unobtrusive indeed. Interesting about his design is that it continuously extracted information about the condition of its wearer and tried to make some sense of it in order to react. This idea of sensing body parameters, without the need for the observer to be physically present, has proven to be relevant to many areas of human activity. Rantanen et al. [2002] have designed a survival garment, consisting of snow jacket and pants, and a special vest to be worn under the jacket, targeting snowmobile drivers in the arctic. Their prototype is intelligent indeed but its bulkiness prevents it from being applied to other usage scenarios. Farrington et al. [1999]

Wearable systems that measure environment or body parameters.

have created a couple of sensing prototypes able to determine body position and dynamics. Even though their work can be used quite well to observe movements of the body, it is only limited to this. Smart clothing showed to be applicable even in medicine with prototypes like the one created by Loriga et al. [2005]. Unlike the systems so far, the one that they presented aimed at sensing only cardiopulmonary signs .

Smart clothing
construction kits.

As wearable computing is a very creative and highly interdisciplinary area of research, there have been a number of workshops to get people interested in the field, as well as some construction kits to help enthusiasts get started. Buechley [2006] used standard electronic components and adopted them for usage with textiles, while Perner-Wilson et al. [2011], on the other hand, relied on what they refer to as a more "artistic" approach for creating smart textile components. The latter work also describes a number of workshops that aimed to educate people with no previous knowledge about smart textiles and assist them in the creation of some simple prototypes. Hurford et al. [2006] have put the stress on the differences between standard engineering tasks and the design and evaluation of wearables. McCann et al. [2005] even describe the whole process for developing smart clothes, stressing on some critical points like identifying end user needs, textile and garment development, integration, manufacture, product launch, and end of life recycling. The above authors have focused on the creation of guidelines for designing smart textile products, standardizing components for their manufacture, and raising general awareness of society about the possibilities in this area.

Wearables
development
process.

Design for eyes-free
interaction.

Aside from the mentioned so far, but very relevant to any wearable prototype, is designing it for eyes-free interaction. Since such designs are mostly intended for use in a mobile context, different interaction paradigms have to be employed due to the fact that the visual channel is occupied with the surrounding environment most of the time. There are two ways to provide feedback under the given context that are usually identified - through touch and through sound. Therefore, we will present a few different approaches for each of them and reason about the selection made for our system.

In the course of this thesis two prototypes were constructed and user-tested. The first one, named *TextiPad*, was a $13.5\text{cm} \times 13.5\text{cm}$ square patch, representing our bare prototype that could be attached with double-sided tape to participants' clothing. The touch sensitive area was a $8\text{cm} \times 8\text{cm}$ square that was located in the middle of the patch. The second prototype, named *GestiPants*, was a pair of jeans with a sensing area on each leg that was again a square with 8cm side. The former was used for target acquisition tasks that were presented to the user as a game, namely an adapted desktop version of the "Wack-a-mole" game. The latter was used for a menu navigation task similarly to the evaluation of *EarPod* done by Zhao et al. [2007]. The navigation commands were invoked through performing a simple gesture on any of the sensing surfaces. The two user studies that we conducted served not only to evaluate our current work but also pointed us to a number of topics for future research. Additionally, we would like to point out that for our prototypes we used highly available hardware and software in order to make it easier for those who are interested to replicate our work.

Two prototypes that were created in the course of this thesis.

In conclusion is a brief summary of the remaining chapters in this work in order to give an overview to the reader.

2—"Related work" lists other publications that discuss wearable input devices and work that served as background knowledge, guiding force and source of motivation for this thesis.

Next chapter, presenting related work.

3—"Prototype requirements" offers a detailed discussion on the requirements that were set prior to design and fabrication.

Requirements for our system.

4—"Design" discusses concepts, suggested by publications prior to our work that influenced the design, the sensor's evolution in a number of iterations, and details about its final architecture. It also describes the design of the various software tools that were needed in the course of our work.

Software and hardware design.

5—"Implementation" provides information about the fabrication of both *TextiPad* and *GestiPants*. It also explains the algorithm that was used for identifying and recognizing gestures in our last application.

Realization of prototypes and gesture recognition.

User studies for evaluating our work.

6—“Evaluation” describes a preliminary and two final user studies that we conducted to evaluate our work. It also presents some findings and insights that we came across while conducting the studies and after analyzing the data.

Optimization of algorithm for gesture recognition.

7—“Post-study optimization” depicts a possible software improvement, affecting the final user study, and demonstrates how it could improve the usability of our prototype.

Contribution of our work and suggestions for consequent research.

8—“Summary and future work” sums up the work that has been done in this thesis and discusses topics of interest for future research that can be done with wearable textile touchpads.

Chapter 2

Related work

There is a number of other publications that influenced this work and also motivated us to design a prototype that compensates for some of their drawbacks. The most relevant are, of course, the ones depicting textile-based devices that handle user input to a primitive software application. Nevertheless, since our ultimate goal is gesture articulation on the sensing surface, we also discuss this topic briefly. This chapter provides an overview of the different approaches for the creation of textile input devices. We have grouped these works in three categories "Discrete input prototypes", "Continuous input prototypes" and "Gesture articulation on garments".

2.1 Discrete input prototypes

One of the major directions, of fabrication of smart clothing prototypes, is through the utilization of conductive embroidery. When mentioning this technique, one usually imagines replacement of the wire connections between components with electrical thread stitched along the fabric, akin to the research done by Linz et al. [2005]. However, much more can be done with conductive embroidery and a number of prototypes have demonstrated that. Komor et al. [2009] have experimented with a variety of spatial layouts for buttons that were realized through raised embroidery

Electrical connections via conductive embroidery.

Conductive embroidery buttons.

with conductive thread on a non-conductive foundation. Thereafter, they have built two prototypes, one with three and another with four buttons, utilizing the button design that proved to be the best in their preliminary tests. Then the authors focused their attention on anchoring interfaces, where one finger is held on a special key while another interacts with the remaining ones (conceptually similar to cut, copy, and paste shortcut commands on a keyboard). They were interested whether such an interaction would be less error prone than a single button press. A large number of prototypes has also been constructed by Holleis et al. [2008], who sewed conductive thread buttons on a phone bag, glove, and apron. Additionally, they experimented with the use of conductive foil to devise buttons on a bicycle helmet. However, most of their research was focused on the apron, where three different button designs were realized with different visibility, and that was also the prototype subjected to user evaluation. Orth et al. [1998] and the consequent research by Post et al. [2000] went even further by creating more elaborate prototypes. Among the ones they fabricated were: a row and column fabric keyboard and a keypad with 12 buttons done via conductive embroidery; a dress and a necklace, whose contact with each other resulted in the dress emitting light; a ball gown also emitting light, where all the circuitry was made with conductive embroidery; toy balls that play music when pressure was applied; an electronic tablecloth, allowing people around the table to interact; and a keypad, transmitting radio signals when its keys were pressed. The first two imply controlling through touch-sensitive buttons, and the focus of the others is either on expressiveness or social interaction. The authors also offer a very detailed discussion on a number of materials and techniques for realizing connections between components, thus, serving as a very firm foundation for following researchers to base their designs upon. Another interesting prototype has been presented by Marculescu et al. [2003]. Their research included a music player embedded in a sweatshirt, with a control keypad fabricated with conductive foil. Even though this prototype also employs a textile button interaction, of large interest is the approach taken for realizing the interconnections between different components. This was accomplished with conductive tape, which is much more robust and requires very little previous experience to utilize compared to conductive

Conductive tape for realizing electrical connections.

embroidery. Unlike any of the works so far, Gilliland et al. [2010] created a number of widgets through embroidery, akin to the ones found in many modern desktop toolkits, employing a plug and play architecture for their use. Thus they had a variety of buttons, sliders, and menus but only one widget could be used at a time, limiting the interaction to only corresponding graphical user interface elements.

Conductive embroidery widgets.

Despite their large number, two significant drawbacks come to the foreground for the prototypes discussed so far - their limited input resolution and lack of dynamics. Since they are capable of providing digital, rather than analog input, the limit of possible values for the device is determined by the number of elements incorporated. Therefore, there is no possibility for producing input, similar to the one of a standard computer mouse for example, by employing the techniques mentioned above. Furthermore, all listed systems lack dynamics since any given element is statically incorporated and tailored only to a particular type of interaction, e.g., button to be pressed or slider to be slid in one dimension. In this line of thought it is interesting to note a phenomenon that we have witnessed over the past decade - the very prominent shift in the way we provide input for one of the most widespread devices. The change from standard screen and keyboard layout to touchscreen on mobile devices afforded the development of new interaction metaphors that complement this new technology. We believe that a similar shift for textile input prototypes is necessary in near future in order for them to keep with the technology trends and this has motivated the creation of *Textipad*.

Drawbacks of conductive embroidered prototypes - low input resolution and lack of dynamics.

2.2 Continuous input prototypes

There have been a few research groups that either built or proposed architectural designs for continuous, textile, touch-sensing surfaces. Since our work is also focused on the creation of a two-dimensional sensor with such properties, we would like to briefly discuss their publications here. Swallow and Thompson [2001] propose two solutions with similar architecture - a fabric switch, similar to

Fabric positional sensor suggested but not implemented.	<p>a standard switch with two states and a fabric position sensor, which actually can identify the exact location of touch across the surface. Both designs incorporate a three-layer model, where two conductive layers are separated with a non-conductive mesh from each other. When sufficient pressure is applied, contact through the mesh occurs and touch is registered. In the case of the fabric switch this means that the button is pressed, and in the case of the position sensor we can obtain the location of the touch through triangulation of the readings at the four corners of the surface. The authors construct a number of prototypes, incorporating fabric switches in soft surfaces like a remote control cushion and a TouchTone musical keyboard. However, none of their systems utilizes a positional sensor, but they still recognize its importance, suggesting that a fabric positional mat would be a "dramatic alternative" to the standard computer mouse. Schiphorst et al. [2005] designed a number of prototype skirts with conductive fabric patterns on their surface. Interesting here is to note that instead of registering touches with finger, the prototypes detect contact with one another, thus having the focus shifted towards the social aspect of the interaction. To enhance their prototype further, the authors also embedded vibrator motors in the skirts that gave varying feedback to the wearer when body interaction patterns between people were recognized. Karrer et al. [2011] created a continuous sensor based on conductive embroidery, allowing the user to provide input by pinching and rolling folds in the textile. Nevertheless, one must note that their system was unidimensional and its resolution was dependent on the number of embroidered lines. Furthermore, the interaction metaphor employed was different, involving deformation of the sensor. Sergio et al. [2002] proposed a capacitive, textile pressure sensor. Conceptually, their system is very similar to ones where the sensor is fabricated through embroidery of rows and columns of conductive traces. However, what distinguishes their work is that the patterns were actually painted on the fabric. Similarly to other embroidered solutions, the limited input resolution of the prototype is once again a limitation to its utilization for more complex tasks.</p>
Schiphorst et al. [2005] mention touch interaction possibility for their prototype but did not utilize it.	
Continuous unidimensional sensor.	
Matrix of elements working as capacitive position sensor.	

The creation of the systems, discussed above, has served to prove that it is possible to produce a sensor capable of reliably locating touch on a textile surface. However, none of

the publications aimed to create a high-resolution, continuous, touch-sensing surface that can be used for tasks similar to the ones achieved with the computer mouse or the touch screen. With the fabrication of *TextiPad* we aim to address this issue and provide a reliable solution for it.

2.3 Gesture articulation on garments

The concept of performing gestures on a worn piece of clothing is not new for the research community. Furthermore, the applicability of this interaction metaphor has already been widely recognized. This fact is supported by the extremely rapid adoption of the gestural input metaphor by the mobile device industry. Early works by Pirhonen et al. [2002] have experimented with gestures, articulated on the touch screen of a Microsoft Pocket PC. Presently the majority of smartphones being manufactured, are complemented with a touch screen, and gestures like pinching and panning have become common even in everyday interaction between people. This fact serves as a starting point for research oriented towards implementation of textile-based systems that support gesture articulation. Saponas et al. [2011] devised a prototype, incorporating a capacitive grid sensor that recognized gestures articulated on it. Despite the system was placed in the pocket and the user actually performed gestures on a garment, it was a stiff, rectangular device, mounted on the back of the casing of a mobile phone. This rigidity afforded machine fabrication, allowing to have high precision and possibility for small size of each capacitive sensor, resulting in a small grid with resolution high enough to allow recognition of letters, drawn on its surface. Nevertheless, one must point out that it would not be possible to embed such a stiff element in a garment without causing discomfort to the wearer. Komor et al. [2009] claim that their button system, which was already discussed, also supported pinching gestures, but one must not forget that there were only a few buttons on their prototypes. Even though that from user's perspective a gesture could indeed be performed, the system obtained very few samples along the articulation. Therefore, the resolution of the gesture was low and applicability to a real world sce-

Initial work in gesture recognition on touch screen.

Typing letters via gestures on the back of a smartphone.

Two button systems that pretend to support gesture recognition.

System allowing articulation of gestures but not trying to distinguish them.

nario is questionable. Cheng et al. [2008] are among the very few to design a textile prototype that supports pseudo gestures to allow doctors to browse documents in a hospital system. However, their work has one major drawback that we would like to point out. Their sensor is a set of seven fabric switches, aligned in linear fashion, thus limiting the variety of gestures to a small number of very similar ones. Moreover, gestures can be articulated only in a single dimension due to the linear alignment, which imposes further limitations to the gesture set. The number of their switches, although larger than that of Komor et al. [2009], is still too low and also results in a low-resolution gesture. Probably the most notable piece of research has been done by Schmeder and Freed [2010]. They have built a fabric touch surface and used different approaches in order to improve the quality of data of their prototype. Unlike Swallow and Thompson [2001], who attached the connections to the microcontroller in the corners of their sensor, here there are two electrodes along opposite edges on one conductive layer, and another two for the other dimension on the other conductive layer. Then, an algorithm for applying and measuring voltage was applied to estimate the location of touches. Even though their experiment involved a gesture being performed on the surface of the sensor, they did not explore the possibility for differentiating between articulations. The discussion of the systems above shows that so far no flexible, textile sensor has been produced, supporting recognition of a number of two-dimensional gestures, articulated by its wearer. This has further inspired the creation of a sensor that ultimately supports articulation and recognition of gestures on its textile surface.

Some of the prototypes mentioned above, have a relatively small resolution, mainly because they are constructed as a one- or two-dimensional grid of relatively large switches, which renders the recognition of gestures on them to be practically impossible. Others have sufficient resolution but either lack the flexibility required for a sensor embedded into clothing, or do not aim at distinguishing simple touches from gestures at all. A number of prototypes with designs similar to *TextiPad* have been built before, but there were no attempts made to recognize a variety of gestures and try to make sense of them in a way similar to what modern touch screen mobile devices do. Also, none of

the publications above, discussing two-dimensional sensing areas like *TextiPad*, identified that such devices are supposed to be part of a piece of clothing. Therefore, many of the sensors were rigid or mounted in a planar fashion, when people interacted with them and the effects of flexibility and curvature were not observed. Also the fact that the human body has a much softer surface, compared to a table for example, may suggest that interaction with a worn sensor is different than when it is lying on a hard surface or mounted in a frame. With this work we aim to answer these questions and ultimately produce a prototype system that supports gesture articulation, recognition and mapping to commands that the user invokes to complete standard tasks.

Chapter 3

Prototype requirements

During the initial stages of this work some general requirements for our sensor were identified, and they should also be applicable to the design of any other smart garment. First, the resulting system should be wearable, meaning that its physical properties should cause minimal discomfort to the wearer (3.1—“Requirements related to physical characteristics”). Second, the design should support eyes-free interaction with the sensing surface in order to afford usage in a mobile context (3.2—“Designing for eyes-free interaction”). Third, it should not break any guidelines already established by other researchers (3.3—“Guidelines”). Lastly, we will strive to use widespread materials so that others are able to repeat our work, which will also allow to keep the price of the sensor relatively low (3.4—“Materials”). We are confident that only if our prototypes satisfy the requirements listed above, they have the potential to become ubiquitous in real-life situations - perceivable when utilized and vanishing in the background when not needed. In order to assure a good understanding for the readers of this publication, we will discuss the listed requirements in more detail below.

3.1 Requirements related to physical characteristics

List of physical requirements.

Just as the creation of a tool for use on the top of a desk has a number of constraints, so does the production of one that is attached on or very close to the human body. We have identified requirements, specific to our device, related to common physical characteristics like size, shape, weight, thermal and electrical properties, and flexibility. They will be discussed in more detail in the following paragraphs.

Appropriate thickness to support flexibility.

The size of the device both in terms of thickness and sensing area of the prototype is of high importance. Common knowledge dictates that for a given material the lower its thickness is, the more flexible it will be. This suggests that a thin sensor will be able to merge better into the remaining garment for a mobile scenario compared to a thicker one. However, one must note that having thicker borders is an advantage, since they provide tactile feedback to the user about the size and location of the prototype.

Appropriate size of the sensing area.

At the same time the sensor should be broad enough to allow the user to achieve his intended tasks, without having the feeling that the borders hinder his actions. Nevertheless, it makes no sense if the area is excessively large such that major parts are not utilized most of the time. To determine the proper size and shape for our sensor, we conducted a small, informal user study with five male, right-handed participants. They were given a thimble with some graphite glued on the tip, and empty sheets of paper. We allowed them to put the thimble on whichever finger they preferred and then place the paper on their thigh at a comfortable location for drawing gestures with the thimble. This location was chosen for reasons that will be discussed in 3.2—“Designing for eyes-free interaction”. Neither the amount of gestures drawn, nor their variety were limited and in case the user was uncertain about what to articulate, the investigator suggested some standard gestures like circle, square, or a cross. This procedure was performed twice - once when the participant was sitting and once when he was standing.

During the study we came across a few interesting observations that are noteworthy. Firstly, all participants, without exception, placed the thimble on the index finger of their predominant hand. Therefore, it was quite likely that during our consequent studies the majority of people would use that finger as well. Interestingly, all participants articulated with their hand loose by the side of the body, thus the drawing area, with respect to their trousers, seemed to be located just below the pocket. Most participants did the same set of gestures across the two treatments and nobody performed the same gesture twice within the same condition. After comparing the sheets from the different participants, we distinguished one user, who performed larger and one, who performed smaller gestures compared to the rest. Additionally, the variety of gestures was large for the small number of people that were involved, and therefore, we suspected that our results would be applicable to the majority of the population and also support a versatile gesture set.

Findings from preliminary study, collecting size requirements.

Regarding the shape of the sensing area we already had some expectations based on the fact that the majority of touch input surfaces are rectangular. In order to define this shape further and to determine its most appropriate size, we decided to process the collected images by drawing a bounding box around each gesture. Then we calculated the average box width and height for each participant, and consequently the mean values among all participants for the two conditions that were offered. The final results showed a size of $75mm \times 83mm$ for the sitting condition and $76mm \times 82mm$ for the standing one. Detailed information about the results and their computation is provided in B—“Detailed results from user studies”. Based on these findings we decided that the most appropriate shape for our sensor should be a square with side $80mm$. Finally, we should also note that due to the placement of our prototype, we must avoid any sharp points or edges to reduce the level of discomfort for the wearer to a minimum.

Appropriate shape for the sensing area.

Results showed square-shaped sensor with side $80mm$.

Weight of the sensor is obviously an important property as well. Diverse fabrics differ in density and materials used in the weaving process, therefore their weight also varies. However, in clothing lightness is often desirable, and in this spirit our sensor should not notably influence the overall

Low weight desired.

weight of the garment.

Thermal and electrical requirements for unobtrusiveness.

Thermal and electrical properties of the sensor are probably the most important physical characteristic due to the fact that extreme values can inflict pain. The sensing area should have thermal characteristics similar to the rest of the garment at any point in time. The sensor should not produce heat that could result in unpleasant feeling for the wearer. All hardware should be selected very carefully to avoid any discomfort or potential harm that electricity may cause. Furthermore, the connections should be insulated appropriately in order to completely eliminate any distress for the wearer.

Flexibility in order to support dynamic wearability.

Lastly, flexibility is also very relevant and some researchers, like Gemperle et al. [1998], have suggested that the form of a wearable should be such that it complies with the curvature of the human body. We are confident that a flexible sensor is much more suitable than a robust one, especially in a mobile scenario, guaranteeing good dynamic wearability of the system.

Definition:
Dynamic Wearability

DYNAMIC WEARABILITY:

The interaction between the human body in motion and the wearable object [Gemperle et al., 1998]

We believe that the physical requirements discussed so far are applicable to the design of any wearable prototype and they should be taken in account by future researchers. With our designs we will strive to satisfy them as much as possible and, therefore, people replicating our work should also comply to them with great attention. A short overview of all requirements related to physical properties is provided in Table 3.1.

3.2 Designing for eyes-free interaction

When designing a wearable prototype, it is not only the physical characteristics that matter. One has to pay extreme attention to the usage scenario that he envisions for his de-

Size and shape	optimal area of the sensing surface minimal thickness raised borders with higher thickness square shape like other touch pads no sharp points and edges
Weight	no notable influence on the overall weight of the garment
Thermal and electrical properties	thermal characteristics like the rest of the garment minimal heat production low electrical values for safety good insulation of connections
Flexibility	sufficient flexibility to afford free movement

Table 3.1: Wearables requirements related to physical characteristics

vice. For a huge number of wearables, their very nature implies usage in a mobile context, where the visual channel is predominantly occupied with the surrounding environment. Therefore, a few additional constraints related to designing a product for eyes-free interaction come into the foreground. In the next few paragraphs we will discuss proper placement of the prototype and various approaches for providing appropriate feedback.

Context determines additional requirements for the system.

In order for a wearable system to be easy to use, it is very important to place the sensors such that they are gropable.

GROPABLE:

Property of a manual interface to allow its user to access and use it with little to no visual attention [Komor et al., 2009]

Definition:
Gropable

Additionally, the location of the sensing area is influenced by its appropriateness in terms of cultural peculiarities and gender. Gemperle et al. [1998] have identified the following areas to be the most unobtrusive for the wearer: collar area; rear of upper arm; forearm; rear, side, and front ribcage; waist and hips; thigh; shin and top of the foot. Since our ultimate goal is the design of an input device that is to be

Previous works investigating appropriate locations for wearables.

Thigh selected as most appropriate location for placing the sensor.

operated via gestures articulated with hands, we can already reject the last two locations, shin and top of the foot, due to the fact that they are not easily reachable by hand for body positions like standing or walking. Holleis et al. [2008] provided a list of appropriate locations for placing wearable touch controls based on results from their study. Their participants identified neck, forearm, hips, hands and thighs as preferred locations, and the thigh area was mentioned most often. Karrer et al. [2011] confirmed the locations identified above as being appropriate for placing textile elements and also added the pocket areas to the list. It is interesting to note that the results from the three works listed so far mostly comply with one another. Thomas et al. [2002] conducted a slightly different study focusing on the appropriateness of the location of a standard touchpad for different body postures. He found that for three of his four defined positions, the front of the thigh was the best one, and for the remaining position - the forearm was superior. He also suggested that if only one location is to be selected, then it should be the forearm, but that would also depend on the assumed context of use. However, digging deeper into his results, one finds that the reason for the forearm supremacy was because one condition involved the user to lie face down on the floor that would render the front of the thigh area absolutely unusable. Moreover, since our prototype is envisioned to be used in a mobile, therefore also social context, we tend to believe that lying on the ground is not likely to happen and consider the front of the thigh to be fitting better our usage vision. Summarizing all sources mentioned above, it becomes obvious that the position most likely to be suitable for our case is the front of the thigh. Therefore, we have selected it as the location, where sensing elements will be placed. For determining the precise location and orientation of sensors for our final prototype, where they would be embedded, we gave a set of simple tasks to participants in our preliminary study and also during the user study for target acquisition (6.1—“Proof of functionality study” ; 6.2—“Target acquisition study”).

An inherent drawback of the mobile context is the fact that the visual channel is mostly occupied with the surrounding environment. Even though providing visual feedback to the user is usually necessary, due to the high perceptive resolution of that channel, one must not solely rely

on it. A number of researchers have identified this limitation of the mobile environment and addressed it in their systems. Some, like Brewster et al. [2003], designed a system that utilized 3D spatial audio for providing feedback to the user. The input modality for their system were gestures, done with head or hand, and in response to that appropriate feedback was provided through audio. Similarly, the Nomadic Radio, designed by Sawhney and Schmandt [2000], uses 3D spatial audio and the location of the sound source is relevant to its occurrence in time. They also utilize varying levels for presenting a textual message to the user starting from silence, ambient sounds, auditory icons and extending to the full body of the message, presented in the background or foreground. For initial prototypes, like ours, that are tested on relevantly simple tasks, we believe that auditory icons are appropriate to inform the user about an occurring event and, therefore such cues will be incorporated in the design to enhance the overall feedback quality. A slightly different approach was taken by Kamel and Landay [2002] in their sketching tool for visually impaired people. They designed the canvas to be recursive and each of its nodes was labelled, so that when the user navigated, he received audio feedback with his current location spoken by the system. Another appropriate channel for giving feedback in a mobile environment is the tactile one. Li [2008] explored the possibility of mapping music to vibrations in two desktop prototypes, simulating two typical touch interactions between people - tapping and rubbing. On the other hand, Oakley and Park [2007] designed a mobile system that used vibrotactile feedback in a menu selection task. The vibrations were applied on the wrist of the wearer, where the whole system was located.

The different approaches for providing feedback listed above are a very valuable addition to any prototype designed for mobile usage. Therefore, we decided to use auditory icons to mark events important for the user to enhance his overall experience with the system. However, we decided to opt out of the provision of tactile feedback due to the fact that our prototype constituted a piece of clothing. For that reason it would need many vibrating motors, which would result in increased complexity and weight of the system.

Suggestion for 3D spatial audio as output modality of the system.

Different levels of audio feedback are possible.

Suggestion for providing tactile and vibrotactile feedback to the user.

Selection of audial feedback as additional output channel of the system.

List of guidelines for the development of smart-textile prototypes prior to our work.

3.3 Guidelines

There are prior publications that list a number of guidelines for designing wearables. Since they are based on experience and feedback, collected during evaluation of the respective system described, we have taken them in account for the design of our own prototype. Gemperle et al. [1998] provided a list of general guidelines for wearability, applicable also to smart clothing prototypes. They discuss the unobtrusive placement of the wearable, support for freedom of movement, small distance from the body and comfortable attachment. The authors also point out that the concavity of the inside surface should match the convexity of the human body. They suggest that wearables should fit as many users as possible and, at the same time, support the physical constraints of used digital technology. Additionally, the authors place importance on weight that does not hinder movement, accessibility of the product, simple and intuitive interaction, aesthetics, thermal aspects and long term use. Another set of guidelines is discussed by Holleis et al. [2008]. They suggest that even simple interfaces assure no clear expectation about arrangement, layout and meaning, thus the localization and identification of controls should also be quick and easy. They also propose that one hand interaction should be assured and immediate feedback provided. Due to the fact that our sensor is a continuous surface, the former requirements are not really applicable since they are specified for discrete input widgets, like the textile buttons of their system. Nevertheless, we will make sure that the location and size of our sensors are perceived easily by the user. The latter rules will also be taken in account by design of a sensor to be operated with one hand only, and provision of immediate feedback about location of the touch visually and important events both through image and sound.

3.4 Materials

The last requirement for our system was to use materials that are largely available on the market, in order for our

work to be reproducible by others. Therefore the microcontroller, used in our design, is an [Arduino](#)¹ Duemilanove that is very popular for rapid prototype creation. The materials used for some of the layers of our sensor, are not so widespread but they can be ordered online. For one of the layers, we used conductive fabric [MedTex180](#)² that proved to be quite robust and fit very well in our sensor. We also used 6mm wide, self-adhesive, conductive, copper tape to realize the connections between the wiring and the appropriate layers of the sensor. The last less-common material was [piezo-resistive foil](#)³, which is usually used for bags to package electronic components. Interestingly, the resistance between two points increases the further they are from each other and this effect is observed simultaneously in both dimensions. The non-conductive mesh fabric and the thin rubber material that we used to keep the conductive layers apart, were bought from a local shop for textiles but their exact type is not that important as long as they have appropriate thickness. For *TextiPad* we used mesh that was 0.20 mm thick, while for *GestiPants* we opted for thicker mesh, which was 0.45 mm thick, due to the expected mobility in the setup of our user study. On the other hand the thickness of the rubber sheet was approximately 1 mm, but one must also note that it is quite elastic in all dimensions. For connecting the sensor to the microcontroller in our last prototype we used [Amohr conductive tape](#)⁴ that is not very common yet, but standard wires suffice as we observed in our earlier prototypes.

Materials used for the fabrication of our two prototypes.

¹www.arduino.cc

²www.sparkfun.com/products/10055

³www.caplinq.com

⁴www.amohr.com

Chapter 4

Design

This chapter will describe the design process for both the hardware architecture of the sensing area and the software used in evaluation sessions with users. Details about the construction of the sensor, according to its final design will be discussed in more detail in the following chapter (5—“Implementation”).

4.1 Hardware design

In this section we will describe in detail the design decisions that had to be made for the hardware part of our system. We will start by presenting factors that influenced the selection of an architecture for the sensing surface. Then we will proceed by explaining some initial experimentation that was made to compare different materials and construction techniques. We will continue by showing the improvements that were made during each iteration of the prototype and conclude by listing the main features of our final sensor design.

4.1.1 Architecture

Deciding whether to create a capacitive or resistive sensor.

Before starting with the construction of the hardware, there was one major decision about our prototype that had to be made - whether it would be a resistive or capacitive touch sensor. In order to decide for one approach or the other, we had to determine what would be feasible under the requirements that were specified. The major limitation was that due to the lack of any specialized textile machinery and equipment, we had to stick to a handmade solution. If we opted for a capacitive sensing area, we had to create a large number of tiny capacitive sensing elements by hand, on which the overall size and resolution were dependent. Furthermore, these miniature sensors had to give consistent readings when compared to one another. We already had some initial results, showing that the size of the sensing area would be 8×8 cm and wanted to achieve a high resolution of at least 50×50 points. This meant that the total number of sensing elements, in the case of a capacitive approach, would be 2500 with approximate size of 1.6×1.6 mm, that would be infeasible under the technology limitations mentioned above. Also, such a large number of elements would increase the complexity of their connection to a microcontroller. Therefore, we decided to build a resistive sensor, that would take much less time and effort, while being far more simple at the same time. It would also allow us to have a large number of sampling points in both dimensions, resulting in a high resolution for the resulting sensor.

Strive for simplicity.

Having selected the type of sensor, there were a couple of other constraints including materials to use for constructing it and duration of the whole project. It was clear to us that using materials that are more easily available, meant that their quality might not be as high as desired, since they were not tailored for our purpose. Therefore, we set one of our main goals to be simplicity in order to have a rapid fabrication process that would allow for making slight modifications and repairs on the sensor very quickly. In this line of thought it is also appropriate to mention a few different architectures for the construction of a resistive, textile, touchpad that have been proposed so far. Schmeder and Freed [2010] suggested an architecture with two piezo-resistive

fabric layers. Each of them had long contact areas on two opposite edges, and the layers were positioned in such a way that the electrodes of one were orthogonal to those of the other. Thus, when one pressed anywhere on the surface, contact through the standoff layer, separating the two conductive layers, occurred and location was estimated by means of an algorithm for applying and reading voltage in a prescribed manner. A number of designs have been suggested by Hannah Perner-Wilson in an online community for sharing ideas - [instructables](https://www.instructables.com/)¹. Similarly to the design above, all her proposals for a location sensing area have two conductive layers, separated by spacing material. The former vary across the three architectures suggested, but there is one that employs a piezo-resistive and a conductive layer. The difference from the previous design is that the electrodes are located in the corners, rather than along the whole edge and also all four of them are on the same layer. However, the functioning principle is also based on contact through the spacing layer in the area of touch. A very similar idea is proposed by Swallow and Thompson [2001], who have the connections in the corners as well, but there is also a fifth one on the other conductive layer for applying voltage. Thus readings from the other four are triangulated to determine the location of the touch. The common between all the designs suggested above is that they constitute of two conductive layers, separated with a stand-off one, and when pressure is applied electrical contact occurs through it. Therefore, we decided to use this as a foundation for the architecture of our prototype as well, and have a layer of piezo-resistive foil with four connections at the corners and conductive fabric one with the fifth connection. For spacing material between the two we decided to use non-conductive mesh material. The sensor area is placed in a textile pocket, constituted by the garment fabric and lining material that help for perceptually merging the sensor with the remaining of the clothing. The complete architecture is represented on Figure 4.1.

Architecture with two piezo-resistive layers.

Three suggested architectures for location sensor.

Another proposed architecture with connections in the corners.

¹www.instructables.com/id/EJKTF3WGV490JGK

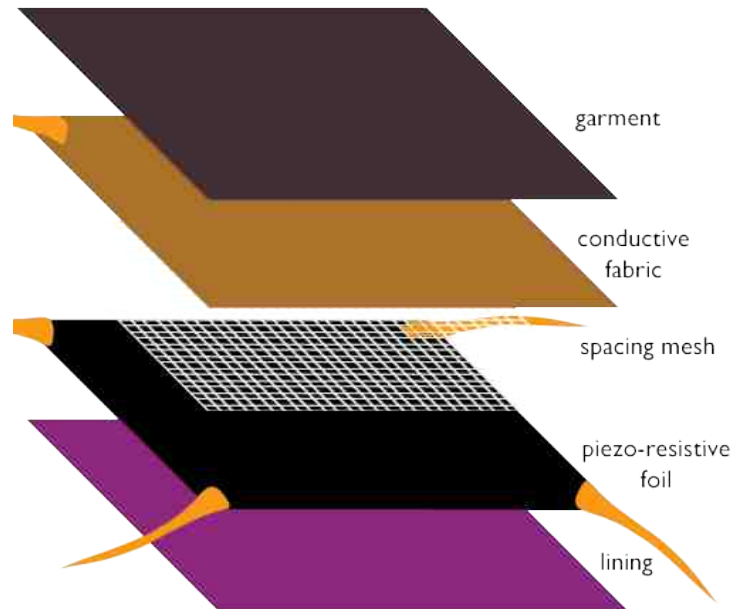

Figure 4.1: Initial layered architecture. The three layers in the middle allow sensing touch and determining its location.

4.1.2 Initial experimentation

After selecting a design, we had to do some initial experimentation with different approaches for realizing the connections to the sensor and a few diverse spacing materials that we had. Regarding the former there were two solutions at our disposition - via conductive thread or via wires. We had to select one that assured reliable and robust contact with the sensor. Obviously conductive thread had to be sewn and we experimented with a few different patterns, but none of them managed to assure good and robust contact. Furthermore, the thread had relatively high resistance compared to a wire with the same length. Therefore, we decided to use standard wires, which required soldering. However, piezo-resistive foil has a relatively low melting temperature and soldering a wire directly to it was impossible. As a first attempt we used small, flat, rectangular pieces of metal that had some holes at one end. So

Experimentation with possibilities for realizing the connection with the prototype.

the wire was soldered to the other end and we used the holes to sew the piece to the piezo-resistive foil. This approach led to much better contact than before, but it was still not reliable enough and we were also afraid that the metallic parts might cause discomfort to the wearer because of their stiffness. Therefore, we opted for another solution that proved to be good enough to be our final one - self-adhesive, conductive copper tape. Soldering to it was very easy and the consequent sticking to the piezo-resistive foil was quite simple, forming a very reliable electrical connection compared to previous attempts.

Next we had to select one of the three samples of spacing mesh material that we had. We had one piece of robust blue mesh with thickness 0.45 mm and two samples with thickness 0.20 mm - a very flexible black and a less elastic white one. The reader can find all of them on Figure 4.2, where lining, piezo-resistive foil with connections in the corners and spacing mesh are held together in a frame structure. In order to determine the most appropriate one,

Experimentation with different spacing mesh materials.



Figure 4.2: Comparison of different mesh materials. The left material is blue, the one on the middle - white, and the right one - black mesh.

we placed conductive fabric on top of the frame, having the fifth wire attached to it, and observed how much pressure had to be applied until contact is registered. We were not surprised that the black mesh required the least pressure and the blue one - the most. However, the white mesh seemed to have a good balance between keeping the layers apart well enough, when no touch was present, and al-

lowing contact to occur without too much pressing force needed. Despite this finding, we decided to create one finished prototype, sewn with a sewing machine along the perimeter, with each type of spacing mesh before making the final decision.

There was one last thing to be done. Having a functioning surface, even though it was only held together by the casing, we were ready to connect it to the microcontroller. The four corners of the piezo-resistive foil were connected to digital pins and either 0V or 5V were applied on each according to an algorithm that will be discussed in 4.2.1—“Design of the microcontroller software”. The fifth wire was plugged in the analog input pin and thus we received a value that was an integer number between 0 and 1023. When no pressure was applied on the sensing area, therefore no contact between the two conductive layers took place, the value read was slightly above the middle of the interval. As a consequence, we had to select a touch threshold that was very close to the upper endpoint of the interval, which was not a good solution. To reduce the reading value we did some further experimentation. We doubled the piezo-resistive foil layer by using a second sheet and placing it back to back with the first one, which actually made the situation even worse. Then we tried to pull the digital pins up, which also did not work well. As a final attempt we pulled the analog reading pin down, and using a $22\text{K}\Omega$ resistor for that proved to be the optimal solution. We also connected the unused analog input pins of the microcontroller together through another $22\text{K}\Omega$ resistor to ground, to reduce noise in the readings. This approach resulted in reading 0 when no touch was present and numbers above the middle of the interval for the other state. These values were very satisfactory, so we were ready to proceed with fabrication.

Enhancing the readings by pulling down the analog input pin.

4.1.3 First iteration of the hardware

The next step was creating a finished prototype, encapsulated in a fabric pocket, as it would appear in its final form. This was achieved by placing the layers in the order shown in Figure 4.1, with wires connected, and sewing the periph-

ery with standard thread with a sewing machine. This resulted in three sensors, one for each different type of mesh, that we placed in casings similar to the frames in Figure 4.2. We proceeded by positioning each encased sensing element on a robust, flat surface and connecting it to the microcontroller to measure when touch was present. Two of them, the ones using black and white mesh as spacing material, registered very high touch values even in relaxed state that did not increase much when pressure was applied on the sensing area. This small difference for the values between the two states meant that there was undesirable connection between the conductive layers. However, when the casing was removed, the sensor utilizing white mesh did not show contact for relaxed state and seemed to work as expected, but the one with black spacing material was still registering erroneous touches. On the other hand, the prototype that used blue mesh did not have the casing problem, but it still required a lot of pressure to be applied before touch could be registered. We then decided to go one step further by removing each of the three sensors from the casing and bending them to observe whether connection between the conductive layers will occur. For the element with black mesh there were high values for contact most of the time while for the other two it occurred only under extreme bending. Based on these findings, we decided to build our further sensors with the white mesh material, although some improvements had to be done to completely eliminate false readings. This meant that a second iteration of the design of our sensor had to be performed.

Sewing the sensor resulted in unwanted contact at the periphery where sewing took place.

Contact occurring for sensor realized with the most flexible mesh.

4.1.4 **Second iteration of the hardware**

The second iteration of the sensor did not involve general changes but just a few improvements. The reason for the unwanted contacts seemed to be caused mostly by the casing and, possibly, also by the sewing applied around the periphery of the surface. To eliminate this we first cut some conductive fabric away from the periphery of the sensor, but since it proved not to be sufficient, we also decided to add some rubber stripes in that same area, whose width was approximately the same as that of the removed electrical garment. The improved scheme for the architecture of

Adding rubber outline to solve the problem with contact at the periphery.

the sensor after the second iteration can be seen in Figure 4.3. We proceeded by performing the same finishing proce-

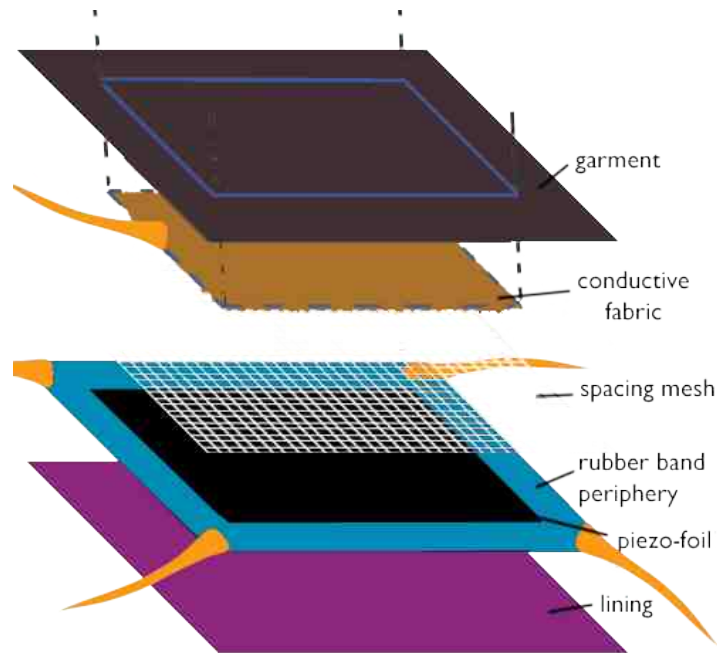

Figure 4.3: Improved layered architecture. Conductive fabric is removed in periphery area of the sensor and replaced by a rubber outline.

dures as before and the final result was much better, resulting in a prototype that was reliably functioning. Therefore, we decided to proceed by creating some more sensors and writing a calibration tool, running on the microcontroller, that mapped the readings to a 100×100 points grid. Details about the software will be discussed later (4.2—“Software design”). However, instead of getting an equally sampled square area, like our touch-sensing surface, we observed values fitting in a warped square like the one on Figure 4.4. At first we came up with a naive solution to use a 10×10 grid and measure representative values for each location on it that we would later use to compute the exact touch location by means of triangulation. Even though this idea worked to some extent, it was not satisfactory due to the extensive calibration process that had to be done manually for each of the 100 points. Thus, it became clear that further improvements to the sensor architecture had to be done.

Extensive calibration
due to warped shape
of the readings.

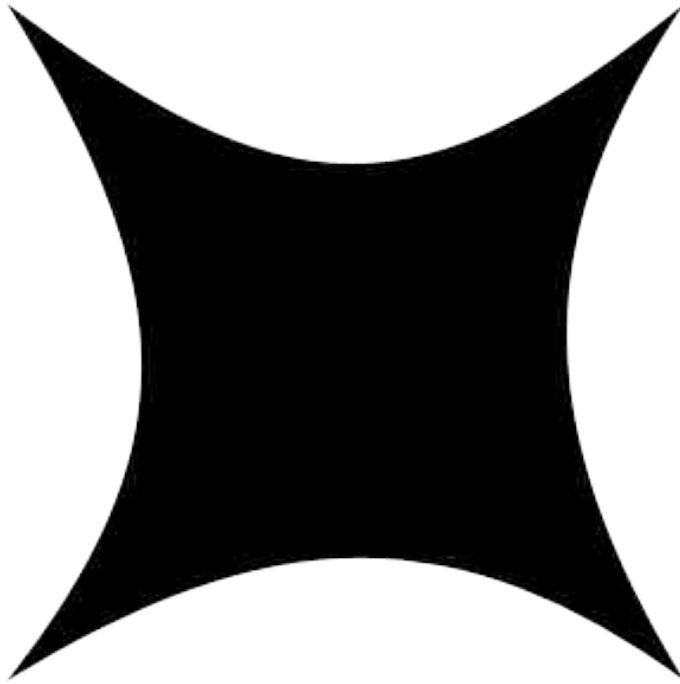

Figure 4.4: Approximate range of sample points. Extreme deformation of readings is present around the center of all four sides.

4.1.5 Third iteration of the hardware

We were certain that the reason for the shape of the sample range was in the placement of electrodes in the four corners of the sensing area. In order to solve this problem, we revisited the publication by Schmeder and Freed [2010], which used long electrodes along the whole edge, and we decided to apply his approach. However, we must point out that since all four electrodes were to be attached to the same layer in our case, we positioned the vertical on one side of the foil and the horizontal on the other, which can be seen on Figure 4.5. There were also a couple of other changes that were related to enhancing the visibility and tactility of the borders of the sensing area. Changing electrode shape and locations meant that we had to do slight modifications to our measuring logic, but on the other hand it removed

Changing electrode shape and placement to obtain proper range for the readings.

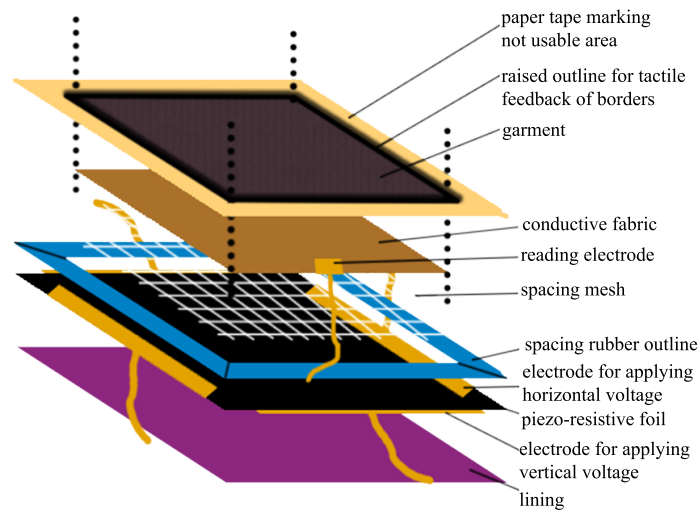

Figure 4.5: Final layered architecture. Electrodes are not placed in the corners anymore, but along the sides of the piezo-resistive layer.

the need for extensive calibration, since the range of readings had the shape of a square. Next, we would like to discuss some general characteristics of our sensor, and the different steps for constructing it, as per the final design, will be discussed in 5—“Implementation”.

4.1.6 Sensor characteristics

Here we will discuss the properties of our final design of a textile, touch-sensing surface. Since our prototype is an input device, it makes sense to compare it to other gadgets, serving similar tasks that are common nowadays. In this respect it makes sense to position it in the design space for input devices developed by [Card et al., 1990], which can be found in Figure 4.6. From this figure one can conclude that the sensor relies on absolute positional readings for the location of touches and on absolute force reading for the amount of pressure applied. However, we must note that the values for location of touch can be used in a way that gives the user the impression of a relative positional sensor,

Prototype shown in the design space for input devices.

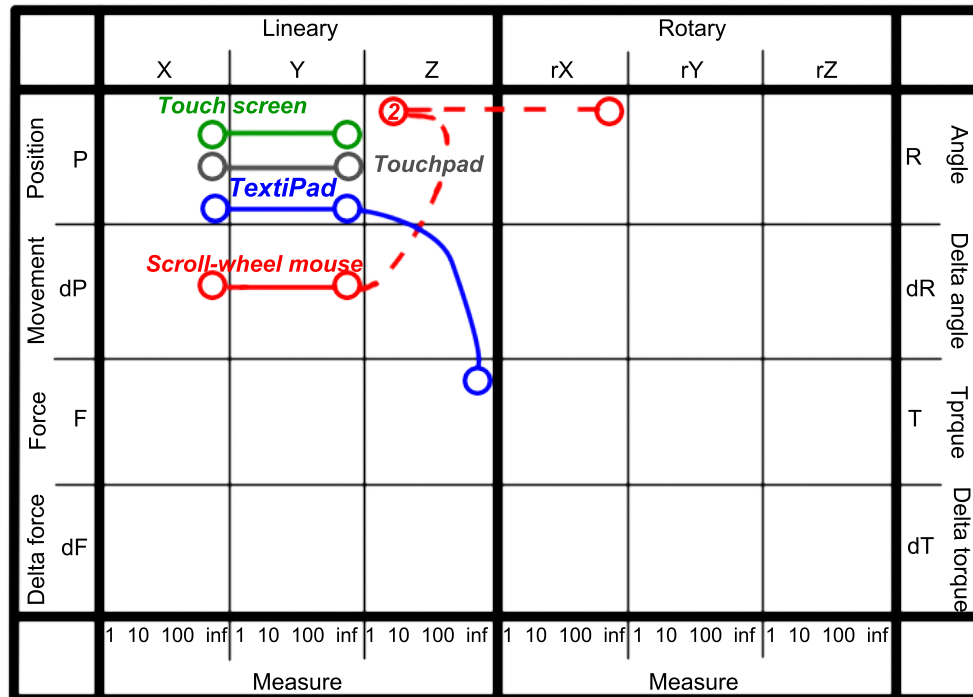

Figure 4.6: Prototype with respect to the design space for input devices [Card et al., 1990]. *TextiPad* is similar to standard touchpad and touch screen with the difference that it also allows obtaining a value for the force applied when touching.

similarly to the way standard touchpad works. At the same time, we obtain theoretically infinite number of values in all three dimensions, since our device is resistive surface, thus, it is up to the microcontroller and code running on it to determine in how many samples the range will be split. The microcontroller that we used applied 10-Bit analog-to-digital conversion, providing a set of 1024 sample values for each dimension. However, in our case this range was not completely covered and we usually obtained around 300 distinct values for the X and Y dimensions, and around 500 for the Z dimension. In addition to the functional characteristics, our sensor employed raised borders of the sensing area for tactile feedback about its size and location. It was also very thin and flexible in order to cause minimal discomfort to the wearer and afford free motion. Despite being hand-made, the sensor proved to be quite robust and accurate, but one must note that there were some areas with

Final input resolution of 300×300 points.

Tactile feedback for location and size.

deteriorated precision, compared to the rest of the surface, probably due to the fabrication process or local irregularities in the building materials.

This section should have provided a general understanding to the reader about the different iterations of the design of our prototype, as well as an idea of what the sensing surface is capable of. The process of building a sensor, according to our final design, will be discussed step by step in 5—“Implementation”. Next we would like to discuss the software design for the applications that were necessary in order to employ our sensing element in a meaningful task.

4.2 Software design

In this chapter we will discuss the various pieces of software that were developed in the course of our work and, more specifically, the design of each of them. We will begin with a discussion on the software that was written for the microcontroller and an initial implementation that displayed the location of touches. Then we will proceed with short explanation of the applications that were used to log and display touch patterns and paths. We will conclude with a discussion of the design decisions relevant to the applications that were implemented for our user studies.

4.2.1 Design of the microcontroller software

Our software design began with a few pieces of code that were very important for the consequent applications - a calibration tool, the microcontroller code and a simple application displaying the locations of touches in an empty canvas. The former two were written for and ran on the Arduino microcontroller, while the latter was written in [Processing](http://www.processing.org)². Both development environments are very similar since Arduino is actually based on Processing. These small applications will be described individually.

²www.processing.org

The calibration tool employed an algorithm for applying voltage in a given pattern and reading the value on the analog input pin and displaying it. The same algorithm was used in all further applications, running on the microcontroller, to obtain a reading from the analog input pin and, thereafter, determine presence and location of touches. For this reason we will describe it in more detail here. The logic consists of five steps that have predefined order and execute at the beginning of each run loop. These steps are visualized on Figure 4.7. The first step puts all digital pins

Five-step scheme for applying voltage.

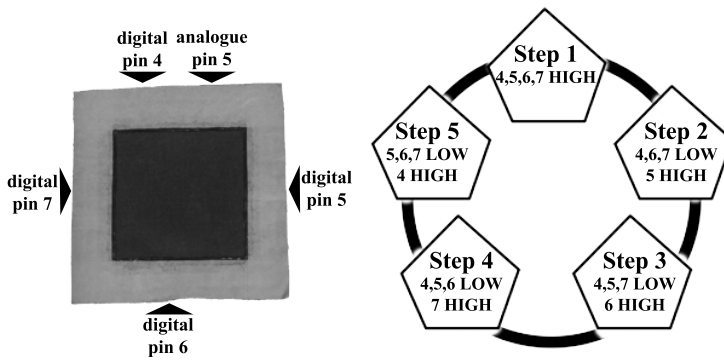

Figure 4.7: Measurement algorithm executed in the beginning of each run loop. On the left is shown the attachment of electrodes to the microcontroller, and on the right - a visualization of the algorithm.

on 5V and reads the value on the analog one in order to determine whether touch is present. The second and fourth steps serve to obtain values for the location of the touch on the horizontal axis, while the third and the fifth - for the location on the vertical axis. All five values, upon being output, serve for calibrating the sensor according to Figure 4.8. First part of the calibration involves pressing the two corners at the top and writing down values measured on steps 3 and 5. Then two means are calculated - one for measurement on step 3 and one for that on step 5 and they are written at the respective places near the top border as per the diagram. Same is done for the bottom border and height can be computed according to the formula:

$$height = \frac{\Delta measurement3 + \Delta measurement5}{2}$$

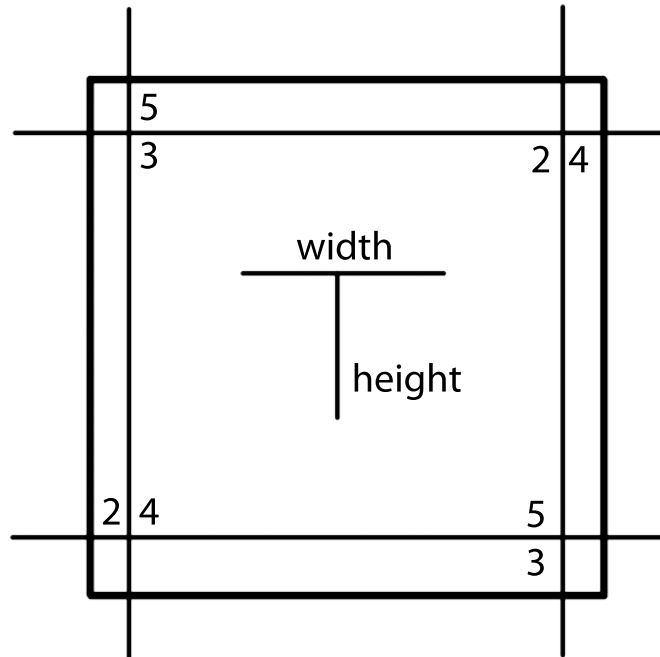

Figure 4.8: Scheme for calibrating the sensor. Two values for each border are extracted and consequently width and height can be computed.

Calibration of the sensor.

In a similar manner one can compute the two pairs of values for the measurements on steps 2 and 4 for left and right borders and, thereafter, calculate the width in the same fashion as above. One can also experiment with applying various amount of pressure and observe the reading on step 1 of the algorithm in order to determine an appropriate threshold for touch registration. With this all calibration values are obtained and one can proceed with the remaining pieces of code.

Algorithm describing the measurement for presence and location of touch.

The next tool was used once the calibration values for the hardware were obtained and did additional enhancement of the data like conversion, clamping, filtering and, if needed, displaying the location of touch. The first step after reading the five values as per the algorithm above, involved converting these readings to meaningful data with the help of the calibration measurements. On one hand,

the value about the presence of touch at the current cycle was determined as the mean of the four latest readings and compared to the threshold before doing anything else. On the other, we used the calibration measurements for the top and left borders and replaced them in the following formulas:

$$\text{bottom-to-top} = \frac{100(\text{currentmeasurement3} - \text{calibrationvalue3})}{\text{calibrationheight}}$$

$$\text{top-to-bottom} = \frac{100(\text{calibrationvalue5} - \text{currentmeasurement5})}{\text{calibrationheight}}$$

$$\text{left-to-right} = \frac{100(\text{calibrationvalue4} - \text{currentmeasurement4})}{\text{calibrationwidth}}$$

$$\text{right-to-left} = \frac{100(\text{currentmeasurement2} - \text{calibrationvalue2})}{\text{calibrationwidth}}$$

Four measurements for determining the location of touch.

The second step involved clamping to assure that touch location values fit within the interval $[0, 100]$. Then the mean of the values computed according to the first two formulas was used as location of the touch on the vertical axis, and the one of the values computed according to the other two formulas - as location of the touch on the horizontal axis. The fourth step involved applying a software filter on the touch locations and below we will reason for our filter selection. Lastly, one must mention that for displaying the touches, a transformation of the coordinate system had to be done, since the prototype assumed that the origin was in the bottom right corner.

Clamping the values.

Final location values computed and filtered over time.

The tool that was written in Processing, on the other hand, was used very briefly to get a visualization of touches before we were able to interface the microcontroller with the development environment, used in our later applications. It was a very simple application that read the incoming values and when touch was present, displayed it as a circle on an empty canvas, resembling the sensor area. For further details about the implementation of the different tools please refer to the source code on the DVD, accompanying this thesis.

Initial tool visualizing the location of touch.

Having made the sequence of steps mentioned above, it became obvious that we had to determine the optimal separation of code - parts running on the microcontroller and ones that ran on a desktop computer. On one hand it was

Separation of code between microcontroller and desktop computer.

Format for the location data.

Comparison of different filters.

1€ filter selected for final implementation.

obvious that conversion and clamping were cheap operations, so we decided to always have them on the microcontroller, and on the other, drawing had to always take place on the desktop computer. To decide for the filtering, we used the Processing tool and experimented between doing it on the microcontroller, and on the desktop computer and came across the following findings. Touch-down and gesture articulation lag times were not perceivably different, but when filtering was done on the microcontroller, there was long, perceivable lag on the touch-up event. At the same time, touch near borders did not show on the visualization under this condition, but was present when filtering was done on the desktop computer. Thus the optimal solution proved to be when the microcontroller code only transformed and clamped the readings to form a 3-tuple of integer numbers. It included two values in the interval $[0, 100]$ for the location of the touch and a third value that served as a flag showing whether touch was present or not, based on the predetermined threshold. These values were then passed further to the desktop computer, where filtering was applied and additional steps for visualization took place.

Nevertheless, since we were also looking for a filter that was optimal in terms of performance and noise removal, we did some further research. We compared a number of filters like a simple low-pass, Kalman, low-pass and then Kalman, and a recently suggested 1€ filter by Casiez et al. [2012], which also uses low-pass filtering to pre-process the data. The last two approaches provided much better quality in contrast to the previous two, so we focused on them in our further comparison. When inspecting them with our Processing tool, we observed that the Kalman filter caused the visualization to lag from the actual position of the finger, which was often perceivable and could go up to a second for quick articulations. On the other hand, no lag was present with the 1€ filter and for that reason we decided to use it in all further implementations. Since the filtering approach was relatively new, there were not many available solutions yet, therefore, we developed one non-object-oriented implementation and one written in Objective-C, that are also part of the contribution of this work and can

be found on the [1€ filter website](#)³. After achieving real-time response from the system, we were ready to proceed with implementing more meaningful software.

4.2.2 Design of an application for drawing input paths

One of the first tools that were developed, was a simple application, showing the location of contact in real time on a canvas. Upon pressing a button, the path of consequent touches was drawn. Screenshots from the application are provided in Figure 4.9 For communication between the mi-

Simple applications showing touch location in real time and drawing its path.



Figure 4.9: Screenshot of application visualizing touch paths. Left image is real time display of touch and right one shows its path.

crocontroller and the desktop computer, we used a class provided on the [Arduino website](#)⁴ that needed some slight modifications to use the data format mentioned earlier. The same interfacing code was used also for the other two applications, which will be discussed next. More details are available in the source code, provided on the DVD, accompanying this thesis.

³www.lifl.fr/~casiez/1euro/

⁴www.arduino.cc/playground/Interfacing/Cocoa

4.2.3 Target acquisition application design

Hiding the target acquisition task in a simple game.

For our first large user study, we decided to present a target acquisition task with circular targets to the participants. The goal of the study and its setup will be discussed in detail in 6.2—“Target acquisition study”, and here we will only focus on the application design. It is relevantly easy to design a spartan user interface for such a task, but we wanted to present an application that would serve the purpose of the study and, at the same time, be fun to use and immerse our participants. Therefore, we decided to implement a variant of the “Wack-a-mole” game, where the user had to hit a mole, by pointing at it using the sensor. When a hit occurred, the next mole showed up and this happened from a random hole every time, where the total number of possible positions was 25. Our solution involved two windows, displayed on the screen, where one was showing an instructional video and the other was the game itself. Screenshots of the latter are shown in Figure 4.10. Since the

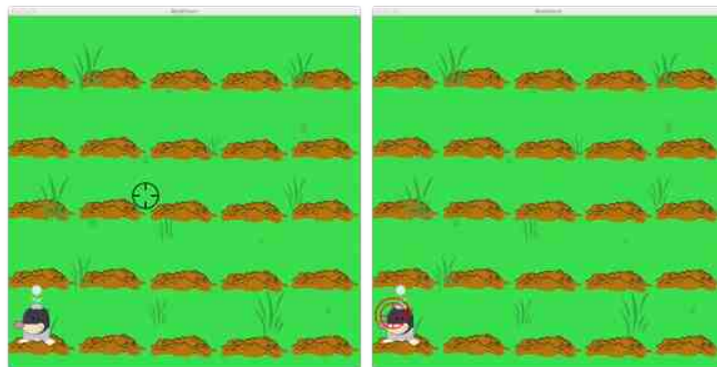

Figure 4.10: Screenshot of application for target acquisition - variant of “Wack-a-mole” game. Left image shows touch far from the mole and right one shows hitting in progress.

shape of a mole is not circular, we processed the image to stress that the target area is a circle, which can be seen on the image. We used a crosshair image for showing the current location of touch, when it was present, and hid it if participant was not interacting with the sensor at the moment. When the crosshair entered the target zone, its color changed to red and a two-second animation showed the

progress of the hitting, informing the user how long he had to remain there. Upon leaving the target zone, the crosshair changed back to black, and in case it was before hit occurred, the animation was invalidated and started from the beginning the following time. There was also audio feedback provided, when the events of mole appearing from the hole and being hit took place. The whole visual part of the application was realized through layers, timers and animations. For measuring the usability of our prototype, we logged task completion time for each individual hit and the location of the touch every 33ms, which was our keyframe rate.

Recorded information for analysis.

4.2.4 Design of gestural menu navigation application

The final user study involved navigating a menu through gestures. Here we will describe the selection of items constituting the menu, its layout, and appropriate gestures for navigating it and depict some further relevant details.

We decided to have a hierarchical menu with two levels like the one used by Zhao et al. [2007] in their user study. The individual items for the menu were the same, but for the final implementation we decided to have eight items on the top level, instead of two, each of which had eight subitems that represented the second level. The complete collection of menu items is shown in Table 4.1. The top row contains the elements on the top level of the hierarchy, or the categories, and the column beneath each of them lists the respective items for the second level of the hierarchy, or subitems for that particular category. For simplicity, we also decided that each articulation will move the current location in the menu by with one position.

Selection of items for the menu.

Further considerations relevant to the menu.

In order to determine the most appropriate layout for the menu, we had short, informal discussions with five students about their preferences and expectations. We explained what the task would consist of and that navigation had to be achieved through gestures, one step in the menu at a time. For four participants this resulted in a layout similar to that of a standard command bar, where all top-level

Layout selection based on user preferences.

Clothing	Fish	Instrument	Job	Animal	Color	Country	Fruit
Apron	Carp	Bassoon	Actor	Ants	Black	Brazil	Apple
Brief	Cod	Cello	Cook	Apes	Blue	China	Banana
Cloak	Eel	Clarinet	Doctor	Bats	Grey	Denmark	Cherry
Coat	Haddock	Drums	Driver	Bears	Green	Egypt	Grape
Dress	Pollock	Flute	Farmer	Eagles	Lime	England	Guava
Hat	Redfish	Guitar	Hunter	Zebras	Navy	Finland	Kiwi
Jacket	Salmon	Organ	Lawyer	Elephants	Olive	France	Lemon
Sweater	Sardine	Piano	Soldier	Horses	Purple	Greece	Mango

Table 4.1: Items used for the menu

items appear as a horizontal list and upon opening a particular one, its subitems are displayed as a column underneath. The fifth interviewee indicated preference toward two parallel vertical lists of items. We selected the former layout due to the higher number of people requesting it. Additionally, we asked for suggestions about suitable gestures to navigate the menu, and everybody proposed linear ones that map to commands in the fashion listed below:

gesture from knee towards the waist - one item down

Gesture to command
mapping.

gesture from waist towards the knee - one item up

gesture from left to right - one item to the right

gesture from right to left - one item to the left

Here, we should note two things - first the list above utilizes direction of gesture from user's point of view, and second, all interviewees were seated during the conversation. The uniformity of the replies determined our choice for a "command-bar-like" layout of the menu, the set of gestures to recognize, and their mapping to commands as already shown. As an example, Figure 4.11 shows the articulation of a gesture from the knee towards the waist, which when done three consequent times results in opening the list of subitems and changing the current position in the menu to the third one of them. There one can also see that the application had a quite simple interface, in which the present position in the menu was indicated by highlighting the respective item background. The menu had struc-

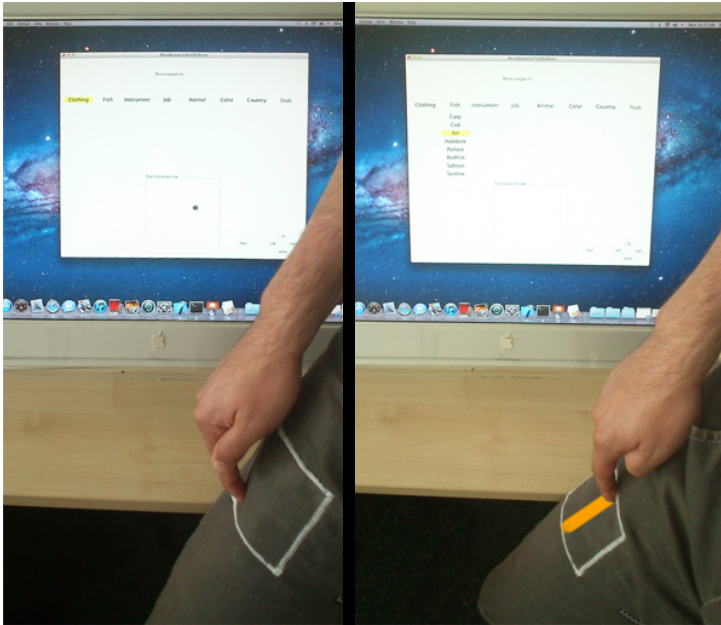

Figure 4.11: Articulating a gesture from knee towards the waist. Left image shows state before and right one - after performing three consequent articulations of this type.

ture such that when current position was in the top level of the hierarchy, the participant did not see the subitems and in order to do so, he had to drill down a particular category. Thereafter, all subitems became visible until going back to the top level. There was also a square view showing the location of touches in real time. The complete user interface of the application can be seen in greater detail on Figure 4.12. Like before, we provided audio feedback that this time enhanced the articulation process. Thus, different sounds were played upon recognizing a gesture, belonging to the known set, and when gesture was identified but was not included in it. For measuring the usability of our prototype, we logged the events of beginning and end of touches on the sensor, the number of touch samples for each gesture, and whether it was recognized or not and its type. Finally, position in the menu, when change from one item to another occurred, was recorded, and location of the touch every 33ms as in the previous application.

Audial feedback for articulations.

Recorded events for consequent analysis.

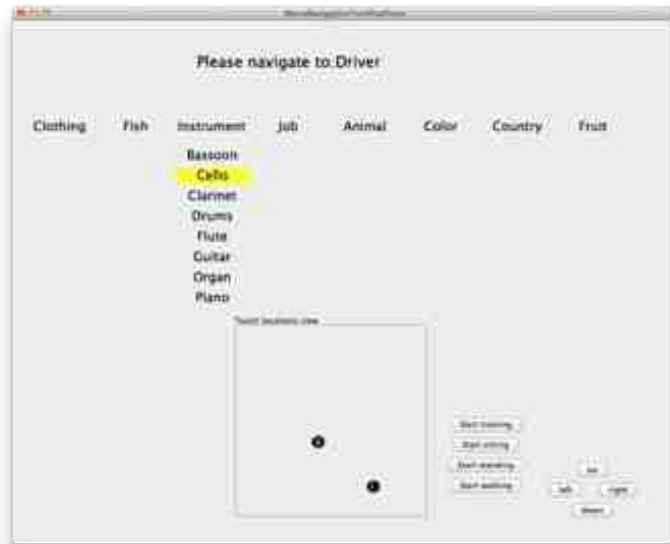

Figure 4.12: Screenshot of application for gestural menu navigation. Position in the menu is indicated by highlighting the respective item and a real time view of the touches is shown at the central bottom area of the window.

All the applications mentioned so far were implemented and ran either on the microcontroller or on a desktop Mac. We will not discuss any further details of the implementation, therefore in case of interest the reader is encouraged to have a look at the source code, available on the accompanying DVD. The following chapter will depict the hardware construction for the two prototypes used in our user studies: *TextiPad* and *GestiPants* and offer a short discussion on the gesture recognition algorithm.

Chapter 5

Implementation

In this chapter we will offer a detailed discussion on the fabrication of *TextiPad* and *GestiPants* - the two prototypes that were evaluated in our user studies. The whole process for creating them, as per the final sensor design that was discussed earlier, will be shown step by step. With this we hope to make it easier for follow-up researchers to replicate our work. In the end we will also describe the steps that were taken for identifying and recognizing gestures, which was part of the menu navigation application for evaluating *GestiPants*.

5.1 *TextiPad*

TextiPad is a prototype with square shape that consisted of a sensing area and small periphery region. The different steps for creating it are depicted in Figure 5.1 and described in detail next. First, we had to cut a square piece of conductive fabric, whose size would determine the sensing area, and mark its borders on both sides of the standard garment 5.1 a), which was the topmost layer. Next, we applied special paper that had heat-activated adhesive on one side, by ironing it with the glue facing the garment - b). On c) one can see that after cooling down, the paper could be peeled off, leaving adhesive on the garment. Next, the conductive fabric was stucked on top, again through ironing - d).

Steps for the creation of *TextiPad*.

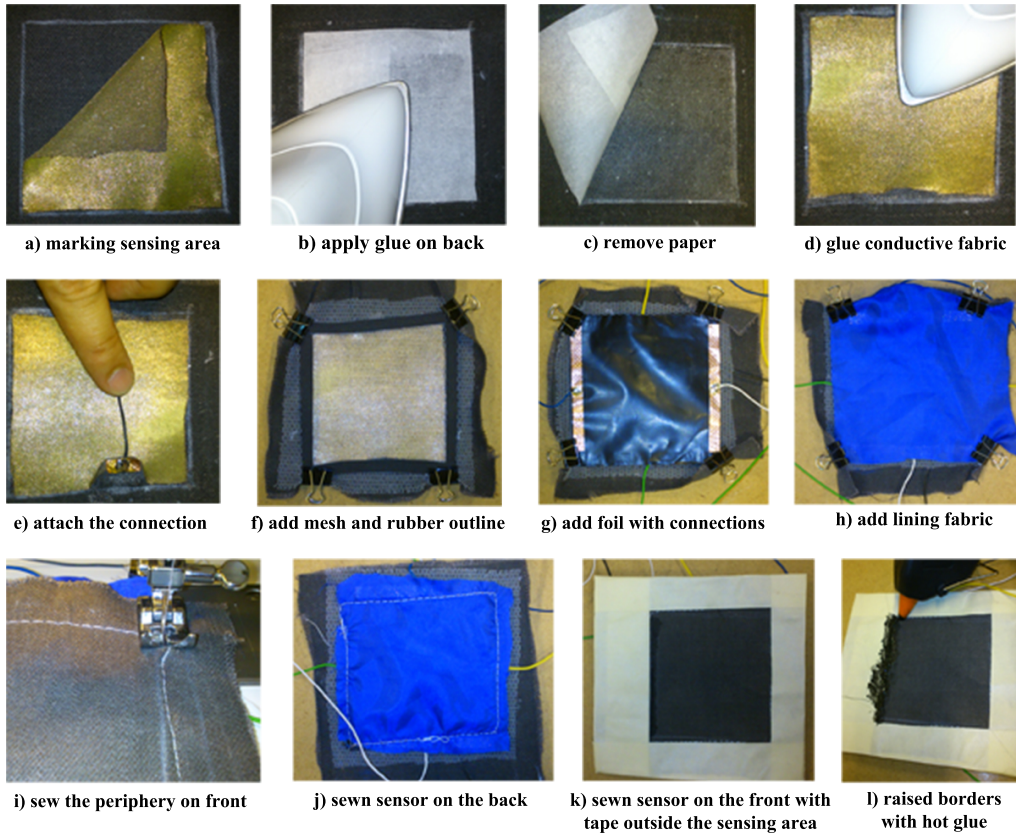

Figure 5.1: Steps for creating *TextiPad*. a) to e) depict adding the first layer, f) to h) the other ones, and the remaining steps are the finishing procedures.

Image e) shows how a piece of copper tape with wire soldered to it is glued to the conductive fabric, such that it is situated between it and the other garment. As a next step we placed a slightly larger spacing mesh sheet and the rubber outline that had to be just on the outside of the conductive fabric - f). We used metal binder clips to make sure that the structure stays aligned from here on. Next, one could add a square sheet of piezo-resistive foil with connections attached according to Figure 4.5, whose size had to match exactly the area that the rubber outline defined - g). Then, the final layer of lining material was added and it had to be approximately of the size of the spacing mesh one - h). After final checks of proper alignment of the layers one could proceed with sewing along the periphery of the sensor, which is shown in i). Since this step was critical, one

had to make sure that the stitches only went through the areas where the rubber outline and copper tape electrodes were located. Having stitches that went on the inside of the copper tape decreased the accuracy and could even render the whole sensor not functional. Image j) shows the back of the sensor with lining material facing up. We did two additional steps to enhance the visual and tactile feedback provided by the sensing surface that are depicted on k) and l). For the visual part we covered the periphery that was not sensitive to touches with paper tape, and for the tactile part we added a thin raised border of hot glue on the inside edge of the tape. We bundled the wires together and connected them to the microcontroller pins as previously discussed. The prototype in its finished form can be seen on Figure 5.2. For attaching it to the wearer's clothing we

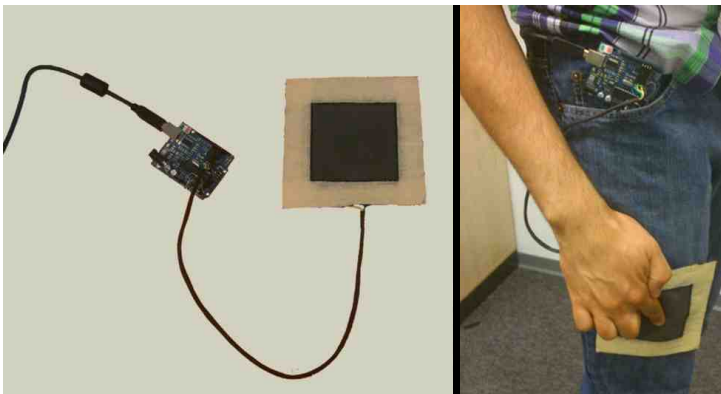

Figure 5.2: Finished prototype ready for evaluation. Left image shows the bare prototype and the right one - its attachment to the right leg of the wearer's jeans.

used double-sided adhesive tape that was applied directly on the lining material at the back of the sensor. Such an attachment to the right leg of the wearer's jeans is shown on the same figure. The remaining of this chapter will give a detailed description of the steps taken to produce an embedded sensor in a pair of trousers.

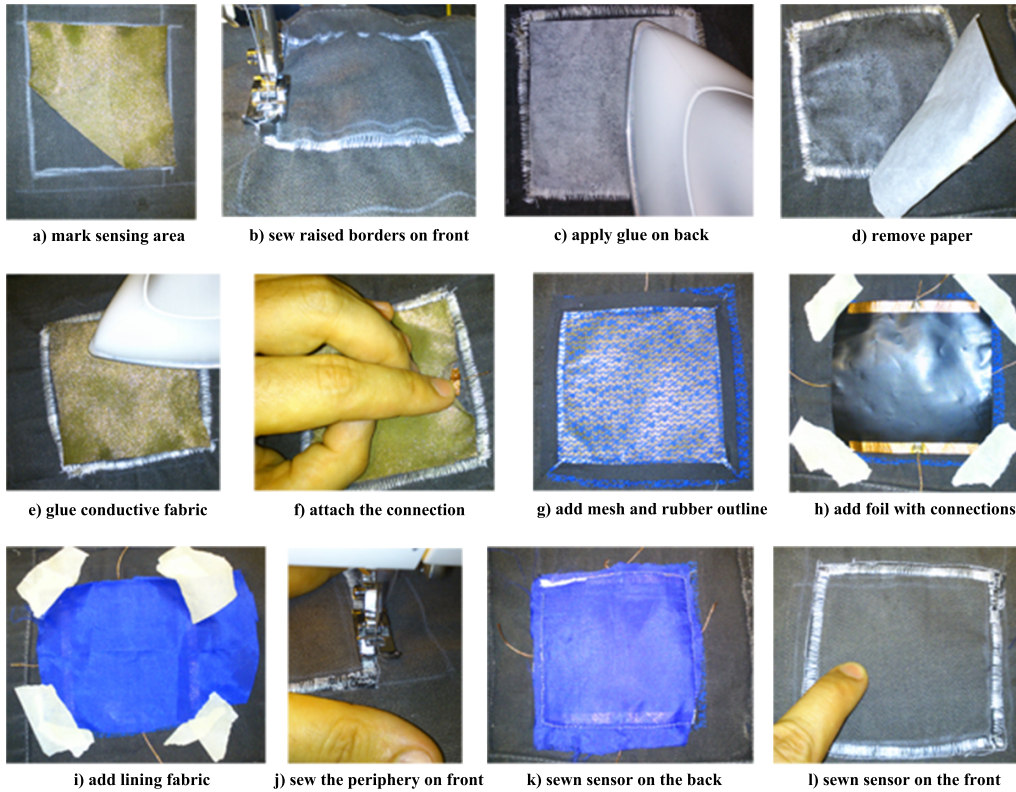

Figure 5.3: Steps for embedding a sensor in *GestiPants*. The difference with *TextiPad* is that sensor borders are done in the very beginning - step b), and the trousers' fabric replaces the textile patch used there.

5.2 *GestiPants*

GestiPants is a pair of trousers that has an embedded sensing area on the front of each leg. Before describing the different steps for the fabrication process, we would like to shortly mention the preparation of the jeans. They were cut at the back, and then along the inside stitches of the legs and elastic velcro straps were sewn at six locations, two at the back and two on the inside of each leg, to allow easy putting on and taking off of the prototype. Also, a small textile pocket was added to hold the microcontroller board. The different steps for creating *GestiPants* are depicted in Figure 5.3 and described in detail next. Similarly to *TextiPad*, the first step involved cutting a square piece of

conductive fabric and marking its borders both on the inside and outside surface of each leg - a). Next, we added borders on the outside, via raised embroidery, using a thin stripe of rubber like the one that was part of the spacing layer - b). Then, we glued the piece of conductive fabric and added its connection in the same way as it was done for *TextiPad* - c) to f). The remaining steps are the same as before, with the only exception that this time we used paper tape to preserve the alignment of layers while sewing with the machine. However, there is one more difference with respect to *TextiPad* that we must point out. Since this time we wanted to enhance the wearability further, we decided to realize the connections to the microcontroller with flexible conductive tape with five copper threads. The exact one that we used was [conductive tape model 03023](#)¹. However, the increased flexibility came to the price of reduced robustness and the areas of the tape close to the sensor tended to break very easily. To solve this issue we used short pieces of standard wire, with removed insulation, that were soldered to the sensor electrodes in one end and to the respective thread from the conductive tape in the other. Then both pieces of tape, one for each sensor, were connected to the microcontroller in a similar fashion as before. Figure 5.4 shows the finished jeans, ready to be used. One can see

Steps for creating
GestiPants.

Realizing the
connections to the
microcontroller with
conductive tape.



Figure 5.4: *GestiPants* - pair of jeans with a sensor embedded in each leg. Left images show the two sensors and right one - the microcontroller placement and insulation.

¹www.amohr.com

Insulating the
conductive tape.

both sensors and the pocket holding the micro controller, sewn in the belt area at the back. We additionally used a special fleece that contained some heat activated adhesive to cover all wires and the conductive tape in order to reduce potential discomfort to the wearer, which can also be seen on the image. To insulate the two pieces of tape from each other, where they connected to the microcontroller, we wrapped them with paper tape. Lastly, Figure 5.5 shows the finished prototype trousers worn, with the two sensors clearly visible. To conclude the implementation part, in the



Figure 5.5: *GestiPants* worn. The two images illustrate that articulation with the same hand on both sensors is possible.

following section we will provide a short discussion on the algorithm used for identifying and recognizing gestures as part of the menu navigation tool.

5.3 Gesture identification and recognition

Here we will offer an overview of the algorithm for identifying and recognizing gestures from the stream of touch readings, received by the microcontroller in real time. The concrete implementation details will not be discussed due to the fact that they are platform and language dependent, thus, in case of interest, we would like to point the reader to the source code available in the accompanying DVD.

First, we would like to point out the difference between identifying and recognizing a gesture. Identification takes

place constantly and it observes the stream of readings for sequences that distinguish touch-down and touch-up events. Only after a gesture is identified, it is forwarded for recognition, i.e., it is compared to a set of criteria in order to match it to one of the gestures that are part of the known set. In the following paragraphs we will discuss each of these steps in more detail.

For identifying a gesture there are two prerequisites: discovering its start and end points, and thereafter confirming that sufficient time has passed between those two events. Detecting start and end of touch on the sensor was done based on the current and previous seven readings, which were put in a queue. Start of touch was identified when all predecessors indicated lack of touch and the current state showed its presence. End of touch was distinguished when all predecessors indicated presence of touch and the current state showed lack of it. Our selection for this particular amount of readings as a threshold was based on the "closed loop" by Card et al. [1986]. Since a reading was obtained every $33ms$, we determined that seven samples had length of approximately $240ms$, thus indicating intentional press-down or press-up event by the user. Then we did some basic experimentation with the sensor to determine appropriate threshold for duration of a gesture and decided that twenty readings were a good choice for our system. Next we will discuss how the identified gestures were compared to a number of criteria during the recognition process.

In order for a gesture to be recognized, it had to match some criteria that defined our recognition set. Due to the fact that we had to recognize only horizontal and vertical lines and their orientation, these criteria were not that complex. For more information on the reasons for the selection of these types of gestures please refer to 4.2.4—"Design of gestural menu navigation application". The first recognition constraint required from the identified gesture to have range along one axis that was at least two times larger than the range on the other. Then, depending on which axis had larger range, the gesture was classified either as horizontal or vertical. To assure that it was a line rather than a steady, noisy touch, matching the mentioned criterion, another requirement stated that the superior range had to span over at least 40 points (out of 100 possible). With this the recogni-

Difference between identification and recognition.

Detecting start and end of touch.

Determining minimal duration of gesture to be $240ms$ based on the "closed loop".

Determining duration constraint through experimentation.

Requirement for linear gesture.

Distinguishing vertical and horizontal gestures.

Span of gesture requirement.

Determining the direction of the gesture.

tion procedure was almost complete and only determining the orientation was left: top to bottom or bottom to top for a vertical gesture and left to right or right to left for a horizontal one. For this the smallest and largest value along the predominant axis were taken and compared with respect to the order in which they were registered by the sensor. This step was also the final one for the complete algorithm for gesture identification and recognition.

With this the whole implementation process for the creation of both *TextiPad* and *GestiPants* has been described. Additionally, we offered a discussion on the algorithmic approach for identifying and recognizing gestures. Having both hardware and software at our disposal, we were ready to put them to a test and verify their usability. The following chapter will provide a discussion on the various user studies that were conducted in the course of this work, and the findings and conclusions that emanate from them.

Chapter 6

Evaluation

In order to evaluate our prototypes we conducted three user studies which will be discussed in detail in this chapter. We will begin with a preliminary study, aiming to confirm the proper functioning of our sensor. Then, we will discuss a large, formal study with main focus on target acquisition, which employed *Textipad*. We will conclude with another large, formal study that presented a menu navigation task, which had to be completed by articulating gestures on the sensors of *Gestipants*.

6.1 Proof of functionality study

The first of a series of formal studies served to prove that our prototype was properly functioning and also to provide us with insights on how people interacted with it. Six participants took part in the study, four male and two female, with an average age of 24 years. One was left-handed and the remaining five users were right-handed. The experiment they were involved in consisted of three parts: initially, the participant articulated on a standard piece of fabric, and the remaining two parts involved actual use of the sensor. Before starting the study, participants signed a consent form, which can be found in A—“Templates used in evaluation”.

Participants
overview.

Articulating gestures on a piece of fabric to determine precise sensor placement and orientation.

The first part of the study required from the user to wrap a large piece of dark fabric around her thigh and draw a sequence of gestures on it, after dipping a finger in baking flour (Figure 6.1). The textile had a few markers that



Figure 6.1: Garment wrapped around participant's thigh for articulating with baking flour. Right hand on right thigh on the left and right hand on left thigh on the right.

were used to assure that the placement is consistent across participants, and attachment was accomplished with velcro fasteners. Participants were first asked to articulate a square and then three vertical and three horizontal lines, performing all of them eyes-free. We observed whether the user guessed the directional mapping on the sensor as per our assumption and noted it down, took a photo of the garment at the end of the session, and cleaned the flour before the next participant. The results from this part of the experiment were expected to provide precise information about the exact placement and orientation of the prototype on the thigh. The findings will be discussed in 6.2—"Target acquisition study" since the same task was presented there in order to increase our sample number and obtain results with higher authenticity.

Measuring undesired contact in sensor for different activities.

The second part involved the application for drawing input paths previously discussed in a scenario where the participants had to perform a predefined set of activities with the sensor attached to their thigh. Users were asked to perform the following tasks: type a short text while sitting, sit and stand sequentially five times, walk around for about ten seconds, jog in place for about ten seconds, jump five times, and do five squats. All tasks were done in the same order across all participants and the occurrence of unwanted contact in the sensor was observed. Its path was recorded as an image at the end of each activity. Undesired contact

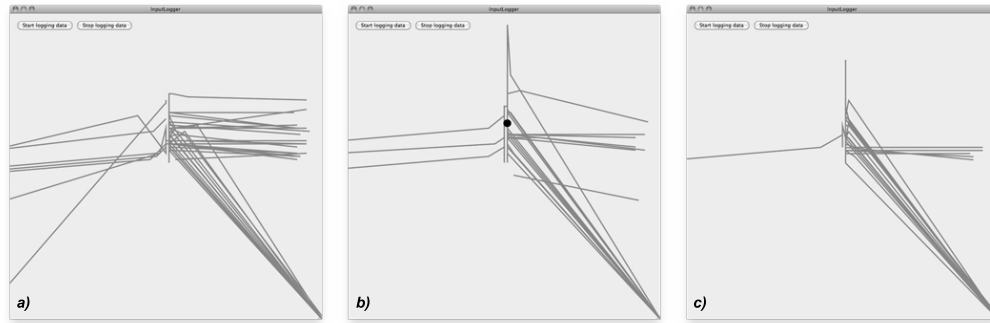

Figure 6.2: Unwanted contact paths. Image a) is recorded for typing, b) for sit and stand sequence, and c) for squats.

was registered for the typing task for all participants and for half of them it was present for long periods of time. The remaining actions showed only occasional occurrences of such signals, which happened most often during the sitting and standing sequence and the squat performance. During all activities contact appeared to be wobbling in the central area, but as one can see on Figure 6.2 there are two main trends for this noise signal. First there is always a diagonal line between the center and the bottom right corner that seems to appear quite consistently in all images. For this reason we assumed that it was either the starting or the ending line in each path, which meant that first and last few readings had to be ignored in future implementations, so that only the actual touches remain. Second is the pattern, occurring as a horizontal line near the center of the canvas that actually represents an unwanted connection. However it seems to be short-timed and occur with high frequency, therefore such patterns had also to be taken care of in our further work.

The third part of the study required from our participants to articulate a set of gestures on the prototype while seated. Like before, the prototype was attached to the user's thigh and the path for each articulation was recorded as an image. The set of gestures included: vertical line, horizontal line, check, circle and x gesture. Each of them was performed five consequent times and in the same order across participants. With this part of the experiment we aimed not only to identify gestures that were easy for people to

Findings from the unwanted contact paths uncovered concerns for following implementations.

Observing initial articulations on the sensor.

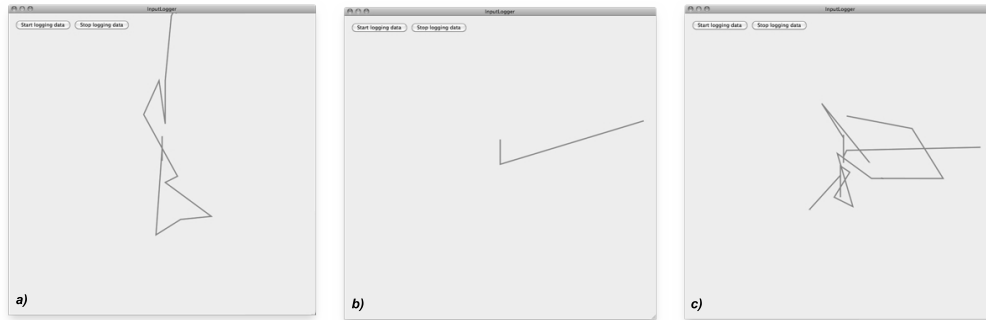

Figure 6.3: Registered gestural paths. Image a) is recorded for vertical line articulation, b) for horizontal line articulation, and c) for circle articulation.

Only simple linear gestures can be articulated well.

Questionnaire about subjective perception of the sensor.

perform, but also ones, whose path of touches most closely resembled the expected trace. We came across a few interesting findings. First, all users articulated rapidly, which was possibly due to their previous experience with standard touch-sensing hardware. Second, the amount of pressure applied on the sensor was too little, and even though we instructed the latter three participants to exercise more force, they hardly reached the value required by our sensing element. Thus, we identified the necessity for providing detailed explanations about how the sensor should be used in the beginning of our consequent user studies. Lastly, we must note that most of the image data showed paths of random shape rather than the expected one. Figure 6.3 shows samples of vertical and horizontal lines, which occasionally were registered as anticipated, and a circle gesture that looks more like random one. Therefore, it became clear to us that for any implementation, requiring gesture recognition, we should stick to simple, linear gestures, since our prototype was likely to recognize them better.

To conclude each session, a short questionnaire was provided that can be found in A—“Templates used in evaluation”. The results showed that four participants noted the size of the sensing area to be appropriate for the tasks presented. Additionally, the visible and tactile feedback that the borders provided was rated very high. People answered differently to the question comparing the sensing surface with standard garment, but there was a small trend pointing towards similarity between the two. Half of the people marked that they were not able to feel the sensor

with the skin of their thigh and the ones who could stated in the follow-up question that this feeling was neither pleasant nor unpleasant. Based on this feedback we decided to employ the prototype in its current state for the next study, which would involve pointing to a target. Since the same set of questions was asked in its end, one can find details about the replies of both groups of participants in a common table in B—“Detailed results from user studies”. The first six rows, with identifiers US1P1-US1P6, contain the answers given by participants in this study. Graphical representations of the results can also be found in B—“Detailed results from user studies”. In conclusion, it is important to note that our observations showed that most participants had no problem with the mapping of sensor to screen coordinates. Everybody guessed the left-right mapping correctly and four participants did so for the bottom-top mapping as well.

This small study provided us with some initial idea of how users would interact with our sensor. The remaining of the chapter will discuss the two formal, large-scale user studies that incorporated our prototypes in scenarios representing real-world situations.

6.2 Target acquisition study

This section will discuss the first of two formal user studies that were focused on completing standard tasks by using our textile touchpad as an input device. A target acquisition task was presented in order to estimate the usability of *TextiPad* for such interaction. We will start with a detailed discussion on the design of the study and proceed with the procedure for conducting it. We will conclude by presenting the results and describing our observations and findings.

6.2.1 Study design

<p>Articulating gestures on a piece of fabric to determine precise sensor placement and orientation.</p>	<p>The target acquisition study consisted of two parts. The first part, similarly to 6.1—“Proof of functionality study”, required from the user to wrap a large piece of dark fabric around her thigh and draw the same sequence of gestures on it, after dipping a finger in baking flour. In 6.2.4—“Results and analysis” we will discuss the overall outcome from this task based on both groups of users.</p>
<p>Pointing to a target in the “Wack-a-mole” game.</p>	<p>The second part involved using <i>TextiPad</i> for pointing to a target under two different conditions: when it was placed on a desk in front of the user and when it was attached to her thigh. Therefore, we set the following hypothesis to be tested with our experiment:</p>
<p>Hypothesis to be checked with the study.</p>	<p style="text-align: center;"><i>H1: There will be no significant difference between the time to complete a task with the prototype placed on a desk, and when it is attached to the user’s thigh.</i></p>
<p>Target shape and size.</p>	<p>To test the hypothesis, we recorded completion time for each individual target acquisition task, which would allow the calculation of average time for each participant under each of the two conditions. However, in order to have the opportunity for more precise analysis, we also recorded information about the presence and location of touch on the sensor every <i>33ms</i>.</p> <p>The target to be acquired had circular shape with radius 35 pixels, which mapped to <i>3.5mm</i> on the sensing surface. In order to complete a task, the participant had to keep the crosshair within the target area for two seconds, without leaving it. For this study we selected a within-subject design due to the simplicity of the task, and the order of conditions was randomized in a balanced fashion. In order to reduce learning effects, training was offered in the beginning of each condition. Next we will discuss the study setup and the procedure for conducting it.</p>



Figure 6.4: Setup for target acquisition study. Left and middle images depict prototype attached to thigh and the right one when it is placed on the desk.

6.2.2 Setup and procedure

During the first part of the study, participants were standing next to a table, on which a bowl with flour and a screen, with slides to mimic the gestures required from them to perform, were placed. For the second part, our users were sitting in front of another desk with a screen on top for displaying the game, and enough space to place the sensor where it would be most comfortable to use. The setup for the second part is shown on Figure 6.4, where both conditions are clearly visible.

At the start of the session, the user had to sign a consent form, which can be found in A—“Templates used in evaluation”. Next, he was asked to fill a questionnaire for determining his handedness, based on the Edinburgh inventory by Oldfield [1971], which can also be found there. Background information was noted down by the investigator and then the first part of the study took place, being conducted in the very same fashion as in 6.1—“Proof of functionality study”. We again took a photo of the articulation paths for consequent analysis, and marked whether the user guessed the directional mapping on the sensor as per our assumption. Next, the second part of the study took place, involving playing a variant of the “Wack-a-mole”

Setup for both parts of the study.

Consent form and handedness questionnaire.

Take a photo of flour articulations.

Target acquisition task for two conditions with training before each.

game that constituted our target acquisition task. For each of the two conditions, the user first exercised ten times and then performed twenty hits, for which data was recorded. The order of treatments across participants was assigned according to a randomization table, generated prior to running the study. After completing both conditions, our users answered the same questionnaire as for the proof of functionality study.

6.2.3 Participants

Summary of the participants in the study.

The target acquisition study involved 26 participants, eight of which were female. The majority were university students and some recent graduates. Five left-handed and one ambidextrous users took part in the study and they were all male. A table with the laterality indices for the handedness of all participants is available in B—“Detailed results from user studies”. One female and one left-handed male used their non-predominant hand for the second part of the experiment. The average age was 25 years, the youngest participant was 18 and the oldest - 34 years old. A questionnaire, answered in the end of the session, required marking one’s experience with touch-sensing surfaces of various types and sizes. We selected three sensors, presently available on the market: touchpad, touch screen and touch-sensing table. The responses are summarized in Figure 6.5. From the box plots one can conclude that on one hand the majority of participants had a lot of experience with touchpad and touch screen technology, but on the other hand touch-sensing tables were not that familiar to them. However, we should point out that our sensor’s size is similar to that of the first two, rather than the last one.

Much experience with touchpad and touch screen but very little with touch-sensing tables.

6.2.4 Results and analysis

We will first present and analyze the results from the first part of the study that involved articulation with baking flour on standard fabric, and consequently discuss the findings from the second part, involving usage of *TextiPad* in a target acquisition task. To conclude, we will shortly present

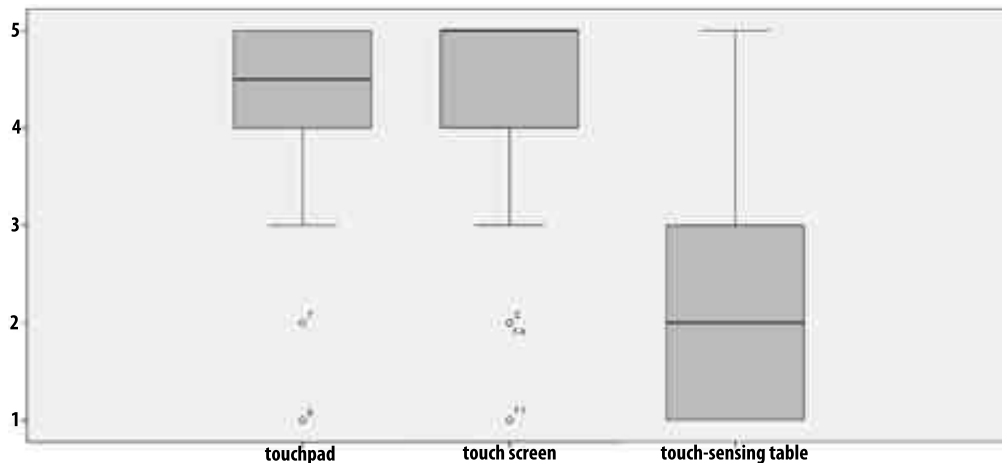

Figure 6.5: Experience with touch-sensing technology for the target acquisition study. The majority of participants have a lot of experience with touchpad and touch screen technology but lack such with touch-sensing tables.

the questionnaire responses regarding the subjective perception of the sensor.

As previously mentioned, the first part of the study incorporated the results from our initial evaluation, 6.1—“Proof of functionality study”, and those from the current group of users. Almost all participants guessed correctly the left-right mapping of sensor to screen coordinates. However, approximately one third of the users were not able to do so for the top-bottom one. Nevertheless, we should stress that this observation was made while participants were standing. We also summarized the image data by creating two maps: a placement and an orientation map. The former overlaid the rectangular shapes, defined by the articulation of a square on the garment, in a semi-transparent manner. This served to produce a map image for the proper location of the sensor on the thigh. The latter incorporated all the linear gestures to determine the correct way to align the sensor with respect to the thigh. We overlaid both maps on top of each other as can be seen on Figure 6.6, in case of interest in the original images, they can be found in B—“Detailed results from user studies”. On the resulting image one can see that the precise location of a sensor, according to our findings, has its center placed $285mm$ down from the edge of the pants on the front of the thigh, and $10mm$

Precise location for embedding the sensor defined.

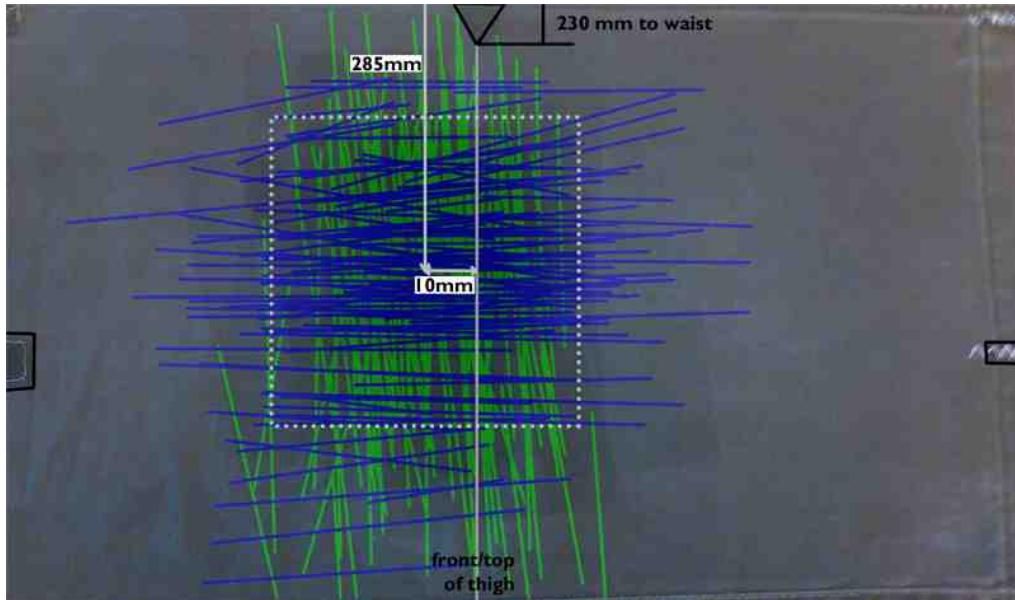

Figure 6.6: Combined placement and orientation map. The image shows that the center of the sensor has to be 285mm down from the waist and 10mm away from the top of the thigh towards its outside with vertical borders parallel to the thigh.

"Cross interaction"
articulating with
predominant hand on
the opposite thigh.

on the outside of the leg, relevant to an axis on its top, connecting the knee and the waist. At the same time the sensor should be oriented in a fashion such that its vertical borders are parallel to the thigh. We came across another unexpected, but quite interesting, observation. Six participants, two right-handed and one left-handed male and three female users, employed an unexpected interaction technique, when articulating gestures with flour. They used their predominant hand to articulate on the opposite thigh, therefore, we called this phenomenon "cross interaction". On Figure 6.1 one can see a comparison of standard interaction, right hand on right thigh for this user, with "cross interaction" where the right hand draws gestures on the left thigh. Thus, this part of the study served not only to provide information about precise placement and orientation of the prototype, but also to show the necessity for embedding a sensor in each of the two legs of a pair of trousers in order to facilitate all possible use cases.

During the second part of the study we came across some other interesting observations. First, nine participants

played the whole game without looking at the prototype at all, which was also occasionally noticed by themselves - one user commented "When playing I didn't look at the prototype". The fact that we came across this with a user group, encountering the sensor for the first time, serves to support its appropriateness for eyes-free interaction. Aside from this we came across a few less common findings that also deserve some attention. Five participants noted that pressing harder resulted in the crosshair to become more stable. Two users shortly lifted their finger off the surface and then pressed on the same place as before in order to improve the stability of the crosshair. Another pair of participants noted that they could tilt their finger while pressing in order to make a slight movement in that direction, similarly to modern touch screens. Additionally, we noted that participants, who used the very tip of their finger for pressing, were able to achieve a less wobbly crosshair, and as a result be more accurate. One participant even pointed out this fact on his own, saying, "When I use my fingertip I am much more precise". Nevertheless, it was also noted by some users that different areas of the sensing surface had different accuracy, probably due to the hand fabrication of the prototype. We also saw signs of fatigue in a number of participants. These findings meant that first, future studies should not be more extensive than the current one, and second, the prototype seems to fit the occasional, short-term usage scenario envisioned, but might not be applicable for a different one in its current state. Additionally, many of the observations made, served as a source for providing more accurate interaction instructions to the participants in our following sessions.

Since the main focus of the study was to compare the usability of our device under two different treatments, it is interesting to note that for 17 participants the subjectively perceived difficulty, when switching from one condition to the other, also changed. Most of the time this was accompanied with comments like "Here I think it is easier and more precise", and "That is much easier, much, much, much easier", in case the desk placement was the second condition, and "It seems less stable now", and "You should really hold your breath", in case the thigh placement was the second one. These observations were also supported by the data we collected during the sessions. Wilcoxon Signed

Appropriateness for eyes-free interaction proven.

Findings about different interaction approaches across the user group.

Difference between the two conditions noted by participants.

Thigh condition results in significantly higher time needed to complete a task.

Unable to identify significant difference for the initial pointing accuracy.

Size and feedback of the sensor received high subjective ratings.

Ranks test showed that task completion times were significantly worse when the prototype was placed on the thigh ($Mdn = 21.03s.$) than on the desk ($Mdn = 7.75s.$) with $z = -4.432, p < 0.05, r = -0.61$. We can, therefore, conclude that placing the prototype on the thigh increased the time needed to complete a task, compared to the case where it was located on a desk, resulting in rejection of the null hypothesis $H1$. In order to get a better idea about the possible reasons for this effect, we extracted information about initial pointing accuracy from our log files. It was determined by the distance between the location at the moment when stable touch-down on the sensor occurred, and the one when task was completed. We also ran a Wilcoxon Signed Ranks test on the results for initial pointing accuracy and it was not able to discover significant difference between thigh ($Mdn = 9.80mm$) and desk ($Mdn = 9.28mm$) placement with $z = -0.978, p = 0,328, r = -0,14$. In case of interest about further details on the data and the test results, we would like to point the reader to B—“Detailed results from user studies”. The last finding indicated that the reason for the worse performance was in the prototype’s accuracy when placed on a curved, soft surface. However, the design of the study did not allow us to identify whether the curvature, or the softness of the surface, or possibly both factors together affected negatively the performance of our participants. To address this drawback, some small improvements were made in the fabrication of *GestiPants*, namely, replacing the spacing mesh with a thicker one, adjusting the threshold for registering touches, and altering the combination of parameters for the filtering further, in order to obtain more accurate readings.

In conclusion we would like to provide a short discussion on results from the questionnaire that was answered in the end of each session. Box plots with the replies of the first three questions can be found in Figure 6.7. Almost everybody rated the size of the sensing area to be appropriate for the task presented. The visibility and tactility of the borders also received high ratings, rewarding our effort to design a surface for eyes-free interaction. The box plots with the replies of the remaining questions can be found in Figure 6.8. When participants were asked to compare the feeling of the sensing surface to that of a standard garment, they indicated perceived similarity between the two. Even

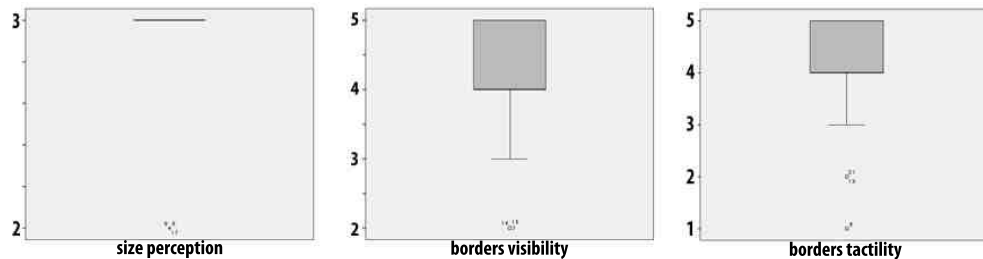

Figure 6.7: Subjective perception of the sensor for the target acquisition study for questions 1-3. Size of the sensing surface was found to be appropriate and the visual and tactile feedback offered by the borders receive very high ratings.

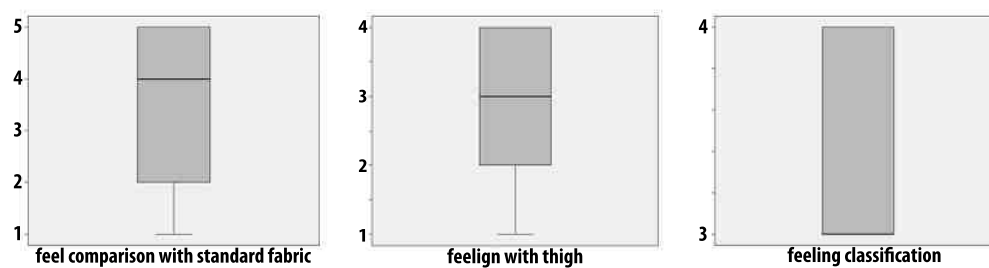

Figure 6.8: Subjective perception of the sensor for the target acquisition study for questions 4-6. Participants identified similarity between the surface and standard garment and did not indicate to be able to sense it with the skin of their thigh.

though this finding is not as strong as the ones before, it supports one of the requirements that were set in the beginning - designing a sensor that allows its unobtrusive merging with the rest of a garment. Most people indicated that they were not able to sense the prototype with their thigh and the very few who did so, indicated that the feeling was neutral, i.e., neither pleasant nor unpleasant. However, we must note that in all cases the sensor was attached on top of one's own clothing, therefore, these results are not surprising. For this reason, we decided to remove these two questions from future questionnaires, since it seemed too obtrusive to ask our participants to replace their own clothing with our prototype, which would be the only solution to render trustworthy answers. The exact questionnaire responses, provided by the participants, can be found in a common table with those for 6.1—"Proof of functionality study" in B—"Detailed results from user studies". The relevant entries for this study have identifiers US2P1-US2P26.

Sensor affords merging in a garment and does not cause discomfort when worn.

With this we have covered all aspects of the target acquisition study, employing *TextiPad* as an input device. In the following section we will offer a detailed discussion on our final user study, which involved navigation in a hierarchical menu through *GestiPants*.

6.3 Study for menu navigation through gestures

This section will discuss the final user study, which was focused on performing another standard task - menu navigation. This was achieved by doing gestures on the sensing area of *Gestipants*, and we evaluated the usability of our sensor in such a task. We will start with a detailed discussion on the design of the study, and proceed with the procedure according to which it was conducted. In conclusion we will present findings and results from the experiment, as well as some general observations made during the sessions.

6.3.1 Study design

We will begin with a detailed discussion about the two parts of the study. Then, we will briefly explain how we designed a path for the walking condition. We will conclude with a discussion on our approach to reduce learning effects between the treatments in the second part of the experiment.

Articulating sample gestures, whose paths were recorded.

The first part of the study was very brief, and involved the application for drawing input paths in a scenario where participants articulated a sequence of horizontal and vertical lines on *GestiPants'* sensors, while sitting and wearing it. The captured images would serve to create a visualization, showing the area of the sensor where such gestures were mostly articulated.

Previous work by Komor et al. [2009] compared stationary and mobile treatment for their conductively embroi-

dered button prototypes. Therefore, for the second part, which constituted the actual menu navigation, we defined three conditions: two stationary ones - sitting in a chair and standing in front of the screen, and a mobile one, involving walking along a predetermined path. During all conditions the participant was wearing *GestiPants* on top of his own clothing, and articulated on the sensors embedded in its legs. For this part of the study we wanted to test the following two hypotheses:

H2: There will be no significant difference in the average gesture duration when user is sitting, standing, or walking along a predefined path.

H3: There will be no significant difference in the recognition rate when user is sitting, standing, or walking along a predefined path.

However, we were able to distinguish between two types of gestures - recognized, and identified but not recognized ones. Therefore, to obtain additional insights, we formulated similar hypotheses for each of them stating:

H4: There will be no significant difference in the average duration of recognized gestures when user is sitting, standing, or walking along a predefined path.

H5: There will be no significant difference in the average duration of identified but not recognized gestures when user is sitting, standing, or walking along a predefined path.

The recognition rate, on the other hand, was also dependent on two parameters - amount of recognized gestures, and total amount of identified gestures. Therefore, two more hypotheses were formulated with the hope to get more fine-grained insights on the data, which are listed below:

H6: There will be no significant difference in the amount of recognized gestures when user is sitting, standing, or walking along a predefined path.

H7: There will be no significant difference in the amount of identified gestures (both recognized and not recognized) when

Comparing articulation parameters under sitting, standing and walking treatments.

Main hypotheses for the menu navigation study.

Complementary hypotheses for H2.

Complementary hypotheses for H3.

user is sitting, standing, or walking along a predefined path.

Dependent variables for the study.

To test these six hypotheses we recorded the events of beginning and end of touches on the sensor, the number of touch samples for each identified gesture to determine its duration, and whether it was recognized or not and its type. Additionally, the position in the menu, when transition from one item to another occurred, was recorded in order to determine navigation errors. Similarly to 6.2—“Target acquisition study”, the presence and location of touch every 33ms was also logged.

Concerns about the path for the walking condition.

We already mentioned that one of our conditions involved walking along a predefined path, while articulating on the sensor. Previous work by Pirhonen et al. [2002] and by Komor et al. [2009] offered such a treatment to the participants in their user studies. Therefore, we designed a path similar to theirs, which can be seen on Figure 6.9, describing the study setup.

Reducing learning effects by offering training before each treatment and using different task sets across conditions.

We applied two different techniques in order to reduce learning effects between the different conditions. First, we offered a short training at the start of each treatment, and second, each condition consisted of a different task sequence. Here we should note that training consisted of three tasks, and an actual condition - of seven, where each task was a target menu item that the user had to navigate to. However, each sequence of tasks was uniformly mapped to a single treatment for all participants. In order to make sure that the set of tasks for a given condition was comparable to that for the others, we defined some requirements. First, the overall number of gestures that had to be performed in a run free of errors, had to be the same - 60 in our case. Second, the number of vertical gestures in a perfect run had to be approximately the same - 13 for sitting, 14 for standing, 13 for walking. Third, the number of horizontal gestures in a flawless run had to also be approximately the same - 47 for sitting, 46 for standing, 47 for walking. To further restrict the navigation path and assure uniformity across participants, we agreed that on one hand, when on the top menu level, only a step to left, right, or down (for opening the subitems list) resulted in change of the state. And on the other hand, when on the bottom level, only a step up or down resulted in change of the state. Further details about

Balancing the three task sets.

the tasks for training and the three conditions are available in A—“Templates used in evaluation”.

With this the discussion of the study design is complete and we will proceed with a presentation of the experiment setup and the procedure for conducting it.

6.3.2 Setup and procedure

During the first part of the study participants were sitting in front of a desk, on which a screen with slides, mimicking the gestures required from them to perform, was placed. The second part consisted of three different conditions, the overall setup for which is schematically shown on Figure 6.9. It involved a computer screen and a large projection

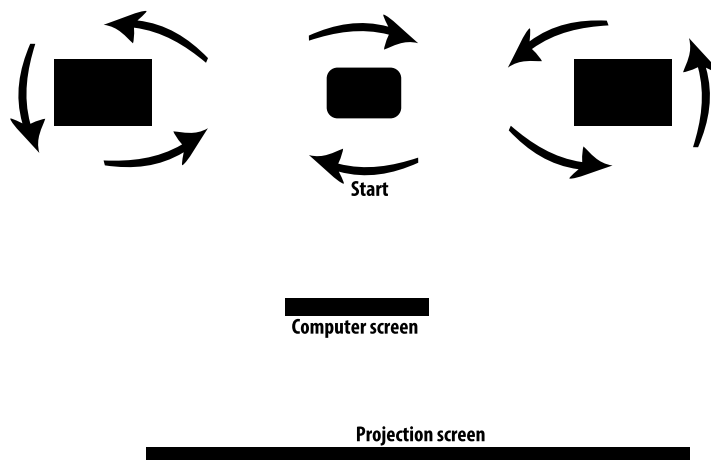

Figure 6.9: Scheme of the setup for the menu navigation study. Arrows indicate the path for the walking condition and the locations of both screens are also shown.

screen a few meters behind it. We opted for additional large screen projection to improve the visual feedback for the walking condition, expecting that some participants might find it difficult to see the menu on the smaller one. However, to assure consistency across all conditions, both displays were duplicated during the whole session. For the sitting treatment, our users were sitting in front of the

Description of the study setup.

computer screen and for the standing condition they were standing at approximately the same distance from both displays. For the walking condition, they were walking along a path, marked with arrows on the floor, a few meters further from both the computer and projected displays, compared to the other two treatments (Figure 6.10).



Figure 6.10: Photos taken of the setup for the menu navigation study. Image on the left depicts the path for the walking condition, while the one on the right shows the displays locations.

Consent for and
handedness
questionnaire.

Like in the other formal studies, at the start of each session, users had to sign a consent form, which can be found in A—“Templates used in evaluation”. Participants were also required to fill the same handedness questionnaire as for 6.2—“Target acquisition study”, and questioned about their general background. Next, *GestiPants* was presented, users had to put it on, with assistance from the principal investigator if needed, and they was asked to select the hand that they would use for the remaining of the session. Then, the first part of the study took place, requiring from the participants to perform gestures that would allow them to move

the cursor in the following directions:

from the bottom to the top of the screen

from the left to the right of the screen

from the top to the bottom of the screen

from the right to the left of the screen

Sample gestures for first part of the study, whose paths were recorded as images.

This procedure was done twice in the sequence of the listing above and an image of the gesture path was recorded after each articulation, resulting in eight images per participant. At this point we also noted down whether the user guessed the directional mapping of the sensor correctly. Between the first and second attempt the participants were given instructions to use the tip of the finger, and find a balance between pressure and articulation speed that would suit them the best. After completing this part of the study, participants were explained that the same four gestures would be used to navigate in a menu under three different conditions for the second part of the experiment which followed. The order of conditions for it was assigned to every participant, according to a balanced randomization table, generated prior to the study. Before each treatment, a short training sequence of tasks had to be completed, and then the actual one, for the respective condition, was started. A log file was created for each participant and treatment, containing both training and the actual sequence of tasks. The latter would be used for statistical analysis, while the combination of the two would serve in plotting the learning curve for each of the conditions. After completing both parts of the study, users answered a questionnaire, which can be found in A—“Templates used in evaluation”.

Conditions performed in a random order.

6.3.3 Participants

The menu navigation study involved 18 participants, three of which were female. The majority were university students and a few recent graduates. Three left-handed participants took part in the study. A table with the laterality indices for the handedness of all participants is available

Summary of the participants in the study.

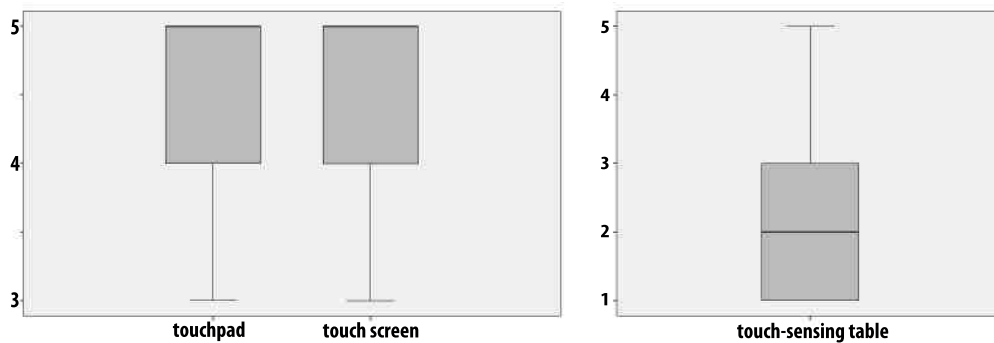

Figure 6.11: Experience with touch-sensing technology for the menu navigation study. The majority of participants have a lot of experience with touchpad and touch screen technology but lack such with touch-sensing tables.

Much experience with touchpad and touch screen but very little with touch-sensing tables.

in B—“Detailed results from user studies”. Session results for one right-handed male were declared invalid, upon him completing the study, due to the fact that he ignored the investigator’s guidance and violated the study requirements numerous times. Therefore, from this point on all discussed results and findings will be based solely on the other 17 users. Their average age was approximately 26 years, the youngest one was 21 and the oldest - 34 years old. Like before, the questionnaire, answered in the end of the session, required marking one’s experience with the same touch-sensing surfaces. The responses are summarized in Figure 6.11 and overall the results are very similar to the ones for the group, participating in the target acquisition study. Once again we would like to stress that our sensor’s size is similar to that of a touchpad or a touch screen, rather than a touch-sensing table.

6.3.4 Results and analysis

Here we will first present and analyze the results from the first part of the study, and consequently discuss the findings from the one, involving usage of *GestiPants* in a menu navigation task. In conclusion we will shortly present the learning curve of our sensor for each treatment and the questionnaire responses, regarding the experience users had during the session.

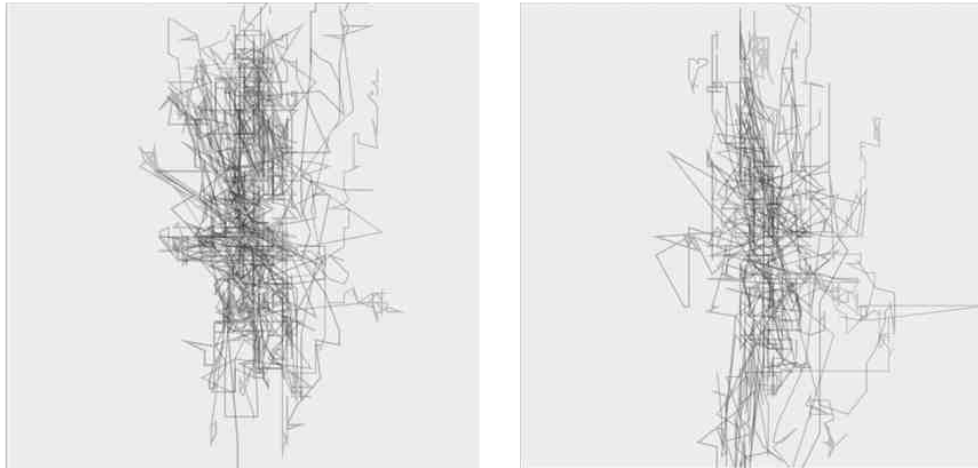

Figure 6.12: Image maps for the two vertical gestures for the menu navigation study. The left one shows bottom to top, and the right one top to bottom articulations.

The findings from the first part of the study can be grouped in two sets. First were the observations of whether participants guessed sensor to screen coordinate mapping correctly. This was true for all users without a single exception during this part of the study, even though later on occasional errors were noted in a couple of cases. However, relating these results to the findings in 6.2—“Target acquisition study” is not possible due to the fact that this time participants were articulating while sitting in a chair, rather than standing. Nevertheless, this could possibly mean that the mapping selected is easier to comprehend in a sitting scenario, thus suggesting that such a setting is probably better for one’s first encounter with a prototype like *Gesti-Pants*. Second was a summary of the image data, achieved by creating an overlay map for each of the four gestures. The ones for the two vertical gestures are shown on Figure 6.12. If we hypothetically split each image along the horizontal axis in three areas with equal size, most of the paths will be contained in the middle one. Therefore, it seems quite likely that users tend to articulate vertical gestures in the central area of the surface. If we compare bottom to top with top to bottom gestures, we can see that the former has a larger spread along the horizontal axis, compared to the latter one. The maps for the two horizontal gestures

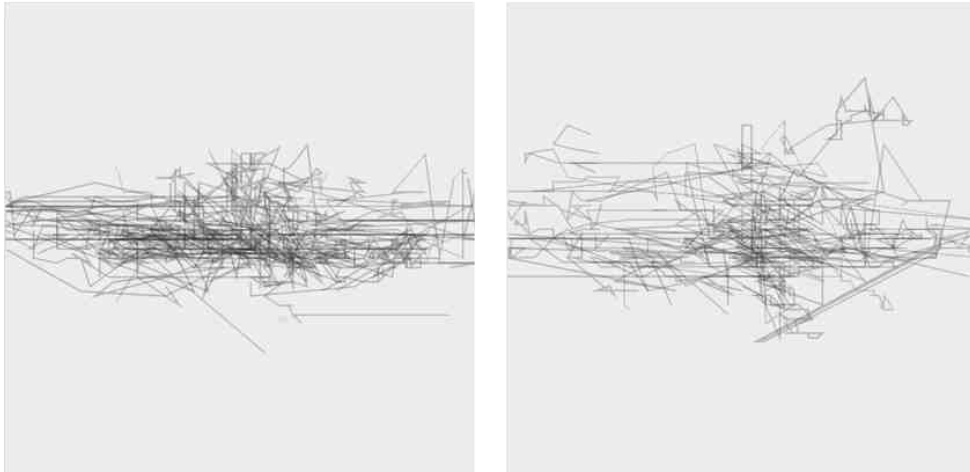

Figure 6.13: Image maps for the two horizontal gestures for the menu navigation study. The left one shows left to right, and the right one right to left articulations.

Tendency for articulating vertical and horizontal lines in the central third of the surface.

Appropriateness for eyes-free interaction confirmed.

are shown on Figure 6.13. If this time we split along the vertical axis in a similar manner, most of the paths will again be contained in the central third. This suggests that users tend to articulate horizontal gestures in the central area of the surface as well. If we also compare left to right with right to left gestures, we can see that the former has a smaller spread along the vertical axis, compared to the latter. Therefore, we can conclude that it is likely for people to perform linear gestures, both vertical and horizontal, in the respective central third of our sensor. It is interesting to note that left to right and top to bottom gestures seem to be more concentrated towards the respective central axis of the sensing surface compared to the other two.

During the second part of the study we came across some other interesting observations. For four participants it was noted that articulation took place without looking at the prototype under all three conditions. Other seven looked at the surface prior to touching it only while sitting, and one did so only while walking, but they all interacted eyes-free for the remaining two treatments. This finding supports further the ones in 6.2—“Target acquisition study”, related to the appropriateness of our design for eyes-free interaction. Another observation showed that participants sometimes used their other hand to hold the prototype, outside

the sensing area, when it was moving too much and interfered with their articulations. We would also like to mention that unlike 6.2—“Target acquisition study”, “cross interaction” was not present here, with the single exception of one user, who preferred the opposite leg sensor under one of the conditions. Our observations also showed that for five participants, articulating a gesture from bottom to top seemed to be the hardest. Nevertheless, four users seemed to articulate vertical gestures more easily than horizontal ones, and for one participant it was the other way around.

Lack of “cross interaction” this time.

Since the main focus of the study was to compare the usage of our prototype under three different conditions, we must mention that this was explicitly noted by a few participants. While sitting one user commented, “I am really terrified for walking”, however, when he started that condition, he said, “It is actually working quite well”. Another one, upon completing the study, commented that he found sitting to be harder than the other two treatments. However, such comments were not made that often, so results from statistical analysis of the measured variables, according to our hypotheses, will be discussed next.

Difference between conditions commented by a few participants.

A Friedman test discovered statistically significant difference in the average gesture duration, depending on the activity while articulating, $\chi^2(2) = 12.706, p = 0.002$. Thus, for the between condition comparison a new significance level of $0.05/3 = 0.017$ had to be used. Consequent Wilcoxon Signed Rank tests identified lack of significant difference for the average gesture duration between the sitting ($Mdn = 1.76seconds$) and standing ($Mdn = 1.75seconds$) conditions, $z = -0.095, p = 0.925, r = -0.02$. However, the average gesture duration for the walking condition ($Mdn = 1.51seconds$) was identified to show statistically significant difference to both sitting ($z = -3.006, p = 0.003 < 0.017, r = -0.52$) and standing ($z = -2.817, p = 0.005 < 0.017, r = -0.48$). We can, therefore, conclude that walking condition elicits a statistically significant decrease of the average duration of gestures and reject H_2 . Subsequently, we ran tests on the average duration of recognized gestures, and the average duration of identified but not recognized ones. Friedman test identified a statistically significant difference for the average duration of recognized gestures, depending on the activity while articulating them,

Gestures are done significantly faster when walking compared to both sitting and standing.

No condition stands out for average duration of recognized gestures and average duration of identified but not recognized gestures.

Recognition rate is significantly worse when walking compared to both sitting and standing.

No condition stands out for amount of recognized gestures and amount of identified gestures.

$\chi^2(2) = 7.373, p = 0.025$. Thus, for the between condition comparison we had to use again a significance level of 0.017. Post hoc Wilcoxon Signed Rank tests showed significant difference in duration of recognized gestures between the standing ($Mdn = 1.99seconds$) and walking ($Mdn = 1.74seconds$) conditions, $z = -2.533, p = 0.011 < 0.017, r = -0.43$. However, no statistically significant difference was found between sitting ($Mdn = 1.98seconds$) and standing conditions ($z = -0.155, p = 0.877 > 0.017, r = -0.03$), and between sitting and walking conditions ($z = -2.344, p = 0.019 > 0.017, r = -0.40$). For the average duration of identified but not recognized gestures a repeated measures ANOVA test could not discover statistically significant difference between activities, $F(2, 32) = 3.136, p = 0.057$. The results from the additional statistical analysis determined the rejection of $H4$ on one hand, but failed to reject $H5$ on the other.

A repeated measures ANOVA test, with ln data correction to obtain normal distribution, showed statistically significant difference for the recognition rate between activities, $F(2, 32) = 9.170, p = 0.001$. Post hoc tests, using the Bonferroni correction, revealed a slight degradation of recognition rate from sitting to standing activity (59% vs. 55% respectively), which was not statistically significant, $p = 0.685$. However, recognition rate degraded to 46% for walking, which resulted in a statistically significant difference compared to sitting ($p = 0.011$) and standing ($p = 0.017$). We can, therefore, conclude that walking as an activity elicits a statistically significant degradation of the recognition rate and reject $H3$. Subsequently, we ran tests on the amount of recognized gestures, and the amount of identified ones. Friedman test did not show statistically significant difference for the amount of recognized gestures, depending on the activity, $\chi^2(2) = 2.981, p = 0.225$. A repeated measures ANOVA test determined that the amount of identified gestures (both recognized and not recognized) differed significantly between activities, $F(2, 32) = 6.414, p = 0.005$. Post hoc tests, using the Bonferroni correction, revealed that significant difference in the amount of identified gestures was present between sitting ($Mdn = 113.64$) and walking ($Mdn = 141.86$) conditions, $p = 0.024$. However, no significant difference was found between standing ($Mdn = 125.71$) and walking ($p = 0.105$), and between sit-

ting and standing ($p = 0.416$). The results of this part of the statistical analysis failed to reject $H6$, but succeeded in rejecting $H7$. Further details are available in B—“Detailed results from user studies”.

Another goal was to obtain a learning curve for our prototype under each treatment. The most appropriate quantifier for measuring the learning effect on our participants seemed to be the recognition rate. It was chosen because of the fact that it was a measure showing the amount of recognized gestures, related to the total number of articulations. In order to obtain an accurate learning curve, we took only measures from the first condition that a given participant was subjected to. Then, the results for each of the ten tasks, three for training and seven for the actual treatment, were averaged across participants and a graph was plotted from the resulting values. This graph constituted our learning curves for each of the three conditions and can be seen on Figure 6.14. Interesting to note here is that the 50% recog-

Learning curves obtained for the three treatments.

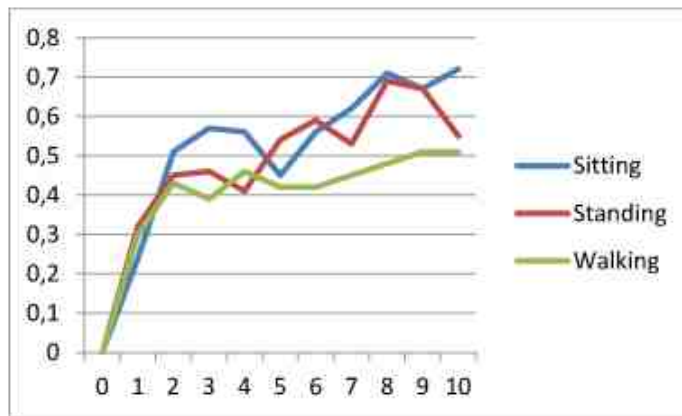

Figure 6.14: Learning curves for all treatments for *Gesti-Pants*. Sitting condition has the steepest curve, suggesting that users grasp the interaction faster while sitting.

niton barrier is first passed with the second task for the sitting condition, the fifth for the standing, and the ninth for the walking one. Due to the relatively small number of samples, the curves have some variation, but one can still see that those for sitting and standing treatments are steeper than that for walking.

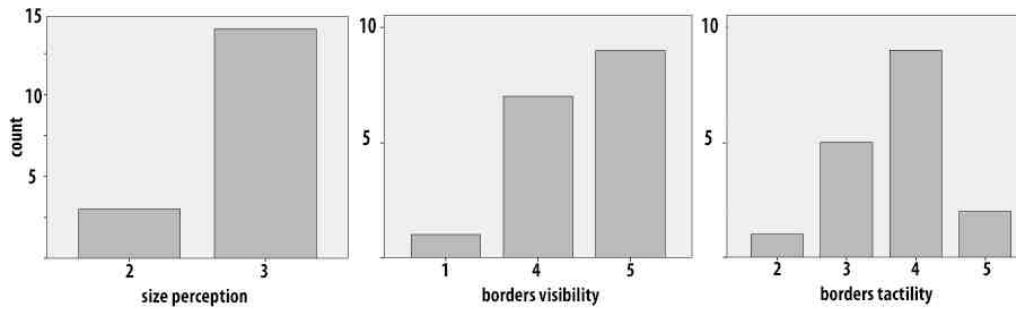

Figure 6.15: Subjective perception of the embedded sensor for the menu navigation study for questions 1-3. Size of the sensing surface was found to be appropriate and the visual and tactile feedback offered by the borders received high ratings.

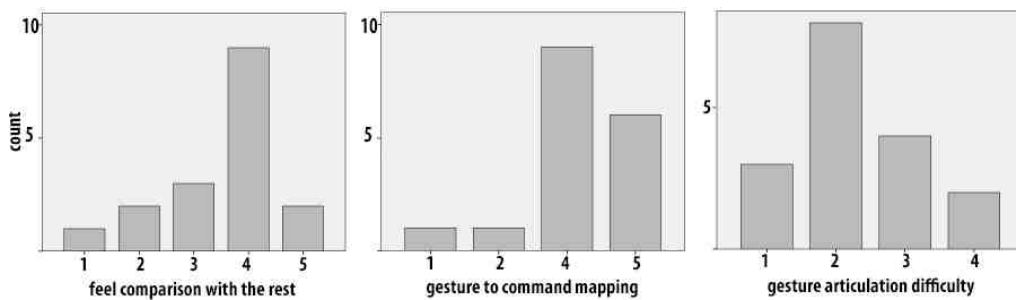

Figure 6.16: Subjective perception of the embedded sensor for the menu navigation study for questions 4-6. Participants identified similarity between the sensing surface and the rest of the prototype, and found the gesture to command mapping to be intuitive, but indicated to have difficulties with the articulation itself.

Size and feedback of the sensor received high subjective ratings again.

Merging of the sensor with the rest of the garment was accomplished.

In the end of this section we would like to discuss the responses to the questionnaire, answered by participants upon finishing the session. Bar graphs, visualizing the replies of the first three questions, can be found in Figure 6.15. Once again, the majority of participants rated the size of the sensing area to be appropriate for the task presented. The visibility and tactility of the borders were once more highly appreciated by the users, rewarding our effort to design a surface for eyes-free interaction. The bar graphs with the responses of the remaining questions can be found in Figure 6.16. When participants had to compare the feeling of the sensing surface to that of the remaining of *GestiPants*, the responses indicated similarity between the two. Since the sensor is embedded beneath the actual fabric, this finding confirms that our goal for unobtrusive merging with the rest of the garment has been reached.

Additionally, users rated the intuitiveness of the selected mapping between gestures and navigation commands to be high, which supports the gesture set applicability for the selected task. Lastly, most of them indicated that performing gestures on the sensor was rather difficult. If we relate this to the results from the previous question, we could suppose that the reason for this perceived hindrance lies in the sensor itself, rather than the gesture set selected. With this all aspects of the menu navigation study, employing *GestiPants* as an input device, have been covered.

Gesture mapping was done well but the articulation was difficult because of the sensor properties.

In this chapter we offered a detailed discussion on the various user studies that were conducted in the course of our work. We began with a small study, aiming to prove the proper functioning of our sensor. Then, the design and findings from two evaluative user studies were discussed in greater detail. The following chapter will present a small, post-evaluation experiment that aimed to discover what the recognition rate would be, if a small optimization of the algorithm was employed.

Chapter 7

Post-study optimization

While conducting the menu navigation study, the principal investigator noted numerous times that participants tended to loose touch in the center of the sensing surface. One participant even commented on this in the following way: "The wrinkles in the textile make it a bit difficult. Vertical gestures are OK but the horizontal ones ..." Our suspicions were also confirmed by the audial feedback, which sometimes sounded more than once as the user made a single articulation. For this reason we developed a small script that parsed the log files from the sessions and tried to merge not recognized gestures, supposedly part of the same articulation, to obtain one, which would be recognized. Obviously two consequent gestures could be merged only if their orientations matched, i.e., they were both either vertical or horizontal. Moreover, their central axes had to be not too far from each other, which is shown on the left part of Figure 7.1. The axis was based on the bounding box around the gesture and we decided that the distance between the ones of articulations being tested, had to be less than 30% of the length of the side of the sensing area. However, there were a couple of other parameters that also had to be decided. First, was the amount of time between the end of the first gesture and the start of the second one. Second, was the distance between the two or in case they were overlapping, the extent of this overlap along the central axis. We added constraints regarding these two parameters, so for the first one we compared the amount of time between the two can-

Drawbacks of the gesture algorithm identified due to hardware specifics.

Requirements for merging two consecutive gestures.

Parameters varied in the merging process like time between gestures and degree of overlapping.

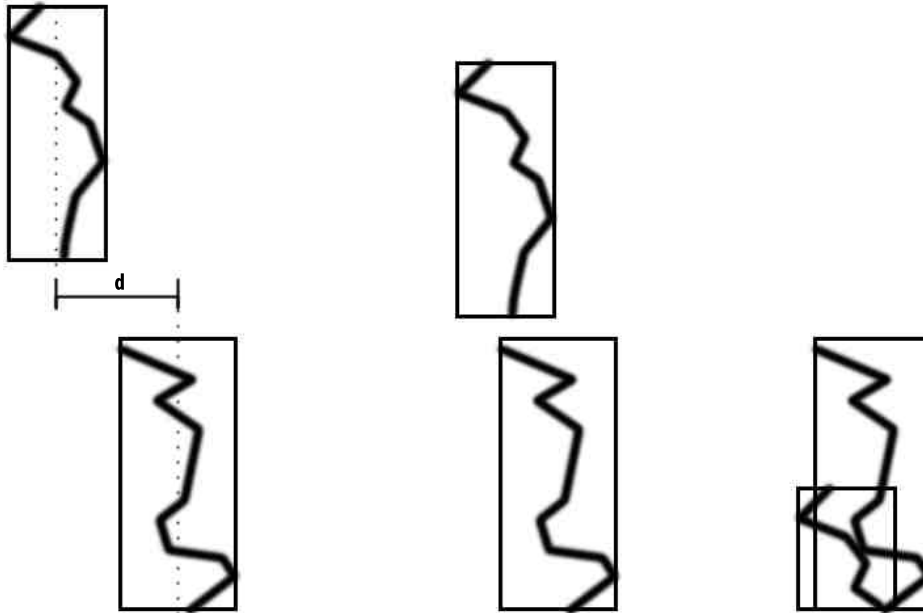

Figure 7.1: Merging gestures that are part of the same articulation. Left pair of gestures denotes the necessity for not too huge distance between gestural axes, one in the middle shows gestures that do not overlap, and one on the right - overlapping ones.

Optimal values identified and small improvement of the recognition demonstrated.

didates with a preselected value. For the second parameter, on one hand if the gestures had the same direction, e.g., they were both top to bottom, they had to either be not too far from each other, or barely overlap. The former is shown in the middle of Figure 7.1. On the other hand, if the direction was opposite, e.g., one was top to bottom and the other bottom to top, they could be merged only if the overlap was significant, visualized on the right in Figure 7.1. We were interested in the number of non-recognized gestures that could be merged to form a recognizable one, when varying the combination of these two parameters. Therefore, we selected six values equally far from one another for the first one spanning from zero to one second. For the other one we selected ten values, also equally sampling the interval between zero and 50% of the length of the side of the sensing surface. The algorithm was run for each combination of parameters issuing satisfying results when overlap spacing was 35% and the time between the gestures was either 0.50 or 0.67 seconds. Lower values for any of the

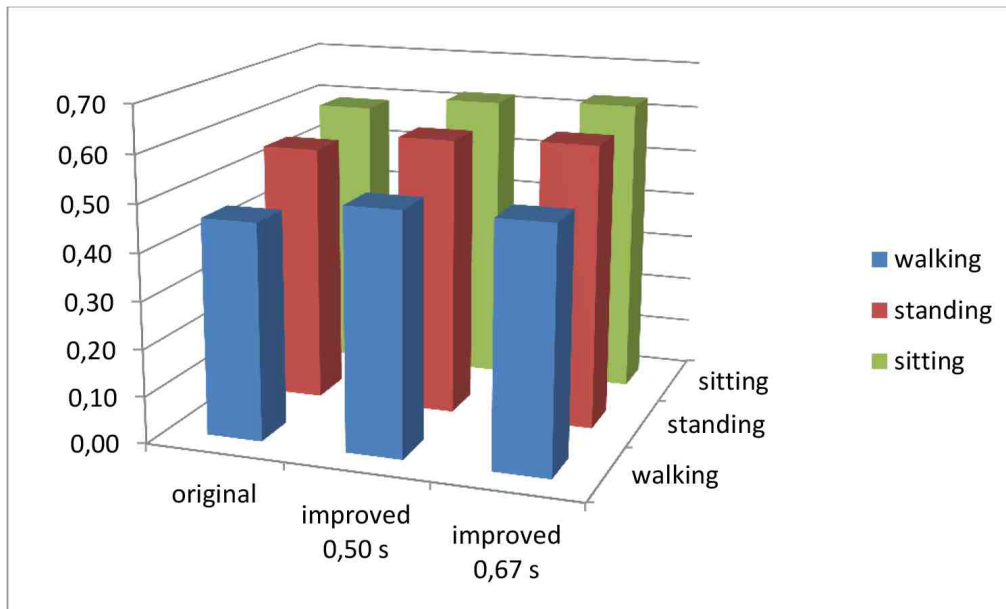

Figure 7.2: Enhancement of recognition rate by merging relevant gestures. A slight increase is visible for each of the three conditions from left (original rate) to right (rate after merging optimization).

parameters resulted in smaller amount of merged gestures, while too high values could result in converging articulations that were meant to be separate. Greater details about the exact results from the optimization can be found in C—“Optimization results”. We believe that such merging step could cause an increase in the amount of gestures recognized, which would also positively affect the recognition rate. A graph comparing the original results with ones in case the improvement was applied can be found in Figure 7.2. There one can see that the recognition rate increases for all three conditions, as a consequence of our optimization. The overall improvement is not huge, but it is a step towards better performance, and potentially an improved user experience. Lastly, we should note that even after the improvement, the overall recognition rate remained relatively low - around 50% to 60%, depending on the condition. This suggests two approaches for further enhancement of the prototype. First, further advancements of the hardware are necessary to obtain more accurate readings. And second, additional care to improve the software is also required. The combination of the two should result in a

significant increase of the recognition rate and, therefore, a more usable system.

In this chapter we have shown one possible way to improve the performance of our prototype for the menu navigation task. This also concludes our work on both *Texti-Pad* and *GestiPants*. Nevertheless, we are certain that further improvements can be made, ultimately resulting in a very accurate sensor and positive user experience with it. In the next chapter we will summarize our work and suggest some directions for consequent research.

Chapter 8

Summary and future work

This chapter offers a summary of our work, denoting issues and reviewing the contributions for the field of human computer interaction. We will also discuss some ideas for future work that mean to point the interested reader to expected further research, and hopefully serve as inspiration for improved implementations of our prototypes.

8.1 Summary and contributions

The main contribution of this work lies in the creation of a wearable, textile touchpad that can be used as an input device in a mobile context. Upon looking at present day products, one can see that the majority of them employ firm controls with various sizes. All of them lack dynamic wearability due to their stiffness, which also impedes the possibility for a seamless embedding in standard garments. Several other textile, touch-sensing solutions, described in 2—“Related work”, have been proposed, but they either lacked flexibility, being mounted in a frame, or offered relatively low resolution. With our work we have shown that it is possible to create a relatively high-resolution, flexible, wearable input device that can be seamlessly embedded in standard fabric and at the same time provide sufficient

We built a wearable, textile touchpad allowing mobile usage.

Present day products lack wearability.

Our prototype has higher resolution and better characteristics for mobile setting than previous ones.

<p>A number of requirement for our prototypes.</p>	<p>feedback to allow eyes-free interaction, which is an essential requirement for usage in a mobile setting.</p>
<p>Defining architecture and designing applications for evaluating the prototypes.</p>	<p>Further goals for the sensor, which we struggled to achieve throughout our work, were specified in 3—“Prototype requirements”. We specified requirements related to the physical characteristics of the sensor, for example about its size, shape, weight, precise location, flexibility, and thermal and electrical properties. We also aimed to comply with previously proposed guidelines and used materials that are easy to find. Last but not least, we strived for simplicity of our overall design.</p>
<p>Defining architecture and designing applications for evaluating the prototypes.</p>	<p>4—“Design” discussed the sensor hardware design and that of the different applications implemented. We described the various iterations that led to our final sensor architecture and offered detailed discussion on it. The software architecture and design were also discussed in great detail, varying from the low-level tools, running on the microcontroller, to the applications that were presented to the participants in our user studies.</p>
<p>Fabrication of <i>TextiPad</i> and <i>GestiPants</i>, and description of gesture recognition.</p>	<p>5—“Implementation” then described the realization both in terms of hardware and software. We demonstrated the production of a sensing element, according to the final design specified in the previous chapter. Furthermore, detailed instructions with the steps required to fabricate both <i>TextiPad</i> and <i>GestiPants</i> were provided. We also explained the algorithm for recognizing gestures from the stream of readings, arriving from the microcontroller.</p>
<p>Description of the complete evaluation from formulating hypotheses and designing user studies, to analyzing the results and summarizing our findings.</p>	<p>6—“Evaluation” described a number of user studies that were conducted in the course of our work. The design, methodology and results from a preliminary user study were discussed, as well as those for the two, involving larger groups of participants and constituting the final evaluation of our work. The preliminary study served to confirm the sensor’s proper functioning once it was assembled. Then, a formal user study involving 26 participants, took place to compare table with thigh placement of the sensor for a target acquisition task. The thigh placement elicited significant difference to the table placement for task completion time, showing that more time was needed under the former treatment. Another formal study involving 18</p>

participants investigated the influence of the activity performed, while articulating gestures in a menu navigation task. A walking treatment elicited significant difference for both average duration of identified gestures and recognition rate, compared to sitting and standing ones. More specifically, we identified faster articulation of gestures and lower recognition rate for the walking condition. At the same time, questionnaire replies from both studies showed that the size of the prototype, determined from previous findings, was found to be appropriate and the feedback offered by its surface supported eyes-free interaction.

7—"Post-study optimization" offered a short discussion on an approach to improve our gesture recognition algorithm and tried to suggest what the results could look like, comparing recognition rate for the enhanced case with that for the original one.

Small optimization for increasing the recognition rate was done.

8.2 Future work

Certainly, the most immediate work to be done, would involve improving the usability of our sensor when located on the thigh. For this reason we would suggest the design of an experiment, aiming to find the reasons for the discussed deterioration. From the two conditions for the target acquisition study it is possible to identify two factors that varied. First is the curvature of the underlying surface, and second, its relative softness. Therefore, we suppose that either the change of shape, or that of rigidity, or both at the same time resulted in decreased usability of our prototype for thigh placement. For this reason we believe that a further experiment, comparing the accuracy under the suggested conditions, has the potential to identify potential weaknesses of the current design and show how it could be improved.

Further study to identify the reason for the decreased performance for the thigh placement.

Other interesting aspects could involve precise interaction with the sensor when placed on the thigh. Figure 8.1 shows two possible ways for such interaction. On the left a user approaches the surface always from the same direction, relevant to the rest of the body, while on the right this is done

Observing the precise interaction with the sensor when placed on the thigh.

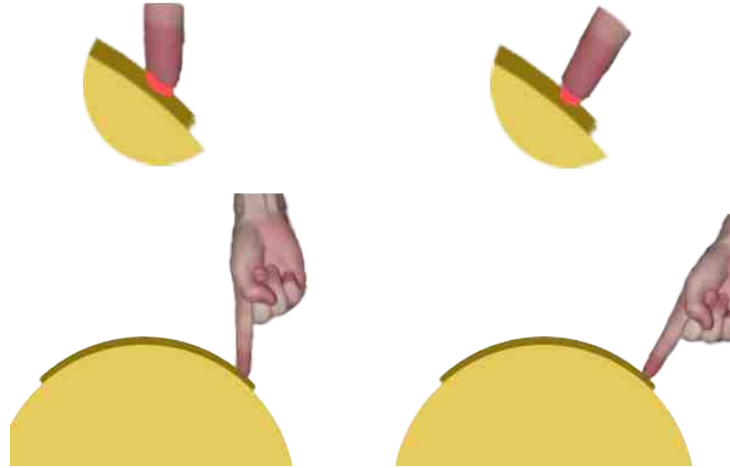

Figure 8.1: Two approaches for interacting with a convex curved surface. Approaching it always from the same direction with respect to the rest of the body on the left, and with finger orthogonal to the thigh on the right.

in a manner, in which the finger is always orthogonal to the tangent plane to the thigh in the point of touch. Other projects, like BendDesk by Weiss et al. [2010], have explored touch interaction with curved surfaces. Since their curve is concave, unlike ours, we propose a similar exploration to be done for our prototype. In this line of thought it would be also interesting to observe the precise orientation of different gestures, articulated on *GestiPants*. A few examples are shown on Figure 8.2. On the left one can see articu-



Figure 8.2: Variance in the orientation of gestures articulated on thigh. Left image shows articulations parallel to the sensor's horizontal borders, and remaining two images depict varying degree with respect to them.

lations of a line, parallel to the horizontal borders of the sensor, while on the middle and right the line is displaced towards the diagonal of the sensing element.

An improved design would also allow for more complex gestures to be reliably recognized, resulting in a larger recognition set. This would also present the opportunity to use established gesture recognizers like the ones presented by Wobbrock et al. [2007] and Anthony and Wobbrock [2010]. Further improvements might make it possible to obtain a more stable reading of the value for presence of touches, and instead of using it as a threshold, map it to a third dimension, allowing 3D gestures to be reliably registered. In the future it would also be interesting to see a textile screen incorporated in the top layer of our sensor, which would allow the creation of a textile, mobile computing device.

Improving the sensor to allow recognition of more complex gestures and possibly 3D gestures.

Addition of a textile display once such technology is available.

Appendix A

Templates used in evaluation

Informed Consent Form

Evaluating "TextiPad" – a touchpad prototype made of fabrics

PRINCIPAL INVESTIGATOR: Stefan Ivanov
 Media Computing Group
 RWTH Aachen University
 Email: stefan.ivanov@rwth-aachen.de

Purpose of the study: The goal of this study is to prove the proper functioning of a textile touchpad prototype. Participants will be asked to "wear" the prototype and perform a set of movements with it. They will also be asked to perform some gestures on the prototype while sitting in a chair. The locations of the touches and gestures, performed on the prototype, will be used in the analysis.

Procedure: Participation in this study will involve three phases. In the first phase you will need to attach a piece of fabric around your thigh and draw some simple gestures on it via a piece of chalk attached to a thimble. In the second phase you will place the prototype on your upper thigh and perform some typical movements like sit and stand, walk, jump etc. In the last phase you will be asked to perform some standard gestures on the surface of the prototype.

After the study, we will ask you to fill out a questionnaire about the tested prototype. In this questionnaire, some general questions will be asked about your habits and practices with respect to computer use and touch surfaces use.

Risks/Discomfort: You may become fatigued during the course of your participation in the study. You will be given opportunity to rest, and additional breaks are also possible. There are no other risks associated with participation in the study. Should completion of either the task or the questionnaire become distressing to you, do not hesitate to terminate it immediately.

Benefits: The results of this study will be useful for improving the functioning and design of the textile touchpad prototype you are about to use.

Alternatives to Participation: Participation in this study is voluntary. You are free to withdraw or discontinue your participation.

Cost and Compensation: Participation in this study will involve no cost to you. There will be snacks and drinks for you during and after the participation.

Confidentiality: All information collected during the study period will be kept strictly confidential. You will be identified through identification numbers. Comments or answers to survey questions may be quoted in publications or reports from this project, but identifying information on any participant will not be included. If you agree to join this study, please sign your name below.

_____ I have read and understood the information on this form.

_____ I have had the information on this form explained to me.

Participant's Name:

Participant's Signature:

Date:

Principal Investigator:

Date:

If you have any questions regarding this study, please contact Stefan Ivanov by email: stefan.ivanov@rwth-aachen.de

Figure A.1: Informed consent form provided to participants prior to the start of the proof of functionality study

TextiPad evaluation questionnaire

Participant ID.....

1. I find the size of the sensing area of the prototype:

too small small appropriate big too big
 1 2 3 4 5

2. I was able to clearly **see** the sensing surface borders.

fully disagree disagree neutral agree fully agree
 1 2 3 4 5

3. I was able to clearly **feel** the sensing surface borders.

fully disagree disagree neutral agree fully agree
 1 2 3 4 5

4. How would you rate the feel of the prototype when using your finger compared to standard fabric?

very different different neutral similar very similar
 1 2 3 4 5

5. I were able to feel the prototype as a whole with the skin of my thigh

fully disagree disagree neutral agree fully agree
 1 2 3 4 5

6. In case you were able to sense the prototype with the skin on your thigh, how would you classify the feeling?

very unpleasant unpleasant neutral pleasant very pleasant
 1 2 3 4 5

7. If you have had any experience with touch based input devices before please rate its amount for the devices you have used.(multiple answers possible)

	1	2	3	4	5
• Touchpad	<u>none</u>	<u>little</u>	<u>some</u>	<u>much</u>	<u>very much</u>
• Mobile device with a touchscreen	<u>none</u>	<u>little</u>	<u>some</u>	<u>much</u>	<u>very much</u>
• Touch sensing table	<u>none</u>	<u>little</u>	<u>some</u>	<u>much</u>	<u>very much</u>
• Other (please write which ones below)					
.....	<u>none</u>	<u>little</u>	<u>some</u>	<u>much</u>	<u>very much</u>
.....	<u>none</u>	<u>little</u>	<u>some</u>	<u>much</u>	<u>very much</u>
.....	<u>none</u>	<u>little</u>	<u>some</u>	<u>much</u>	<u>very much</u>

Figure A.2: Questionnaire filled by participants in the end of the proof of functionality study

Informed Consent Form

Evaluating "TextiPad" – a touchpad prototype made of fabrics

PRINCIPAL INVESTIGATOR: Stefan Ivanov
 Media Computing Group
 RWTH Aachen University
 Email: stefan.ivanov@rwth-aachen.de

Purpose of the study: The goal of this study is to evaluate a textile touchpad prototype for its usability and wearability. Participants will be presented "Wackamole" game on a computer display, where in order to hit the mole, they need to press at the corresponding location on the prototype. Moles will appear from random holes one at a time, and once tapped will hide for the next one to appear. The locations of the touches, performed on the prototype, will be used in the analysis.

Procedure: Participation in this study will involve two phases. In the first phase you will need to attach a piece of fabric around your thigh and draw some simple gestures on it via a piece of chalk attached to a thimble. In the second phase you will be interacting with the prototype under two different conditions: lying on a flat surface and attached to your clothing in the area of the thigh with double sided duct tape. You will be asked to press on the respective location on the prototype until the mole is hit.

After the study, we will ask you to fill out a questionnaire about the tested prototype. In this questionnaire, some general questions will be asked about your habits and practices with respect to computer use and touch surfaces use.

Risks/Discomfort: You may become fatigued during the course of your participation in the study. You will be given opportunity to rest, and additional breaks are also possible. There are no other risks associated with participation in the study. Should completion of either the task or the questionnaire become distressing to you, do not hesitate to terminate it immediately.

Benefits: The results of this study will be useful for improving the functioning and design of the textile touchpad prototype you are about to use.

Alternatives to Participation: Participation in this study is voluntary. You are free to withdraw or discontinue your participation.

Cost and Compensation: Participation in this study will involve no cost to you. There will be snacks and drinks for you during and after the participation.

Confidentiality: All information collected during the study period will be kept strictly confidential. You will be identified through identification numbers. Comments or answers to survey questions may be quoted in publications or reports from this project, but identifying information on any participant will not be included. If you agree to join this study, please sign your name below.

_____ I have read and understood the information on this form.

_____ I have had the information on this form explained to me.

Participant's Name:

Participant's Signature:

Date:

Principal Investigator:

Date:

If you have any questions regarding this study, please contact Stefan Ivanov by email: stefan.ivanov@rwth-aachen.de

Figure A.3: Informed consent form provided to participants prior to the start of the target acquisition study

Handedness Questionnaire

Participant ID:.....

Which hand do you prefer to use when:	Do you ever use the other hand?
Writing:	
<u>Left</u> <u>No preference</u> <u>Right</u>	Yes
Drawing:	
<u>Left</u> <u>No preference</u> <u>Right</u>	Yes
Throwing:	
<u>Left</u> <u>No preference</u> <u>Right</u>	Yes
Using Scissors:	
<u>Left</u> <u>No preference</u> <u>Right</u>	Yes
Using a Toothbrush:	
<u>Left</u> <u>No preference</u> <u>Right</u>	Yes
Using a Knife (without a fork):	
<u>Left</u> <u>No preference</u> <u>Right</u>	Yes
Using a Spoon:	
<u>Left</u> <u>No preference</u> <u>Right</u>	Yes
Using a broom (upper hand):	
<u>Left</u> <u>No preference</u> <u>Right</u>	Yes
Striking a Match:	
<u>Left</u> <u>No preference</u> <u>Right</u>	Yes
Opening a Box (holding the lid):	
<u>Left</u> <u>No preference</u> <u>Right</u>	Yes
Items below are not on the standard inventory:	
Holding a Computer Mouse:	
<u>Left</u> <u>No preference</u> <u>Right</u>	Yes
Using a Key to Unlock a Door:	
<u>Left</u> <u>No preference</u> <u>Right</u>	Yes
Holding a Hammer:	
<u>Left</u> <u>No preference</u> <u>Right</u>	Yes
Holding a Brush or Comb:	
<u>Left</u> <u>No preference</u> <u>Right</u>	Yes
Holding a Cup while Drinking	
<u>Left</u> <u>No preference</u> <u>Right</u>	Yes

Reference: Oldfield, R.C. "The assessment and analysis of handedness: the Edinburgh inventory." *Neuropsychologia*. 9(1): 97-113. 1971.

Figure A.4: Handedness questionnaire according to the Edinburgh inventory [Oldfield, 1971]

Sitting condition				
Gesture set for full path	#gestures for full path	Target item	Location of target item	
			Top level	Sub level
→→→↓ ↓	6	Doctor	4	3
↑↑↑← ↓↓↓↓	8	Drums	3	4
↑↑↑↑ ←←↓↓ ↓	10	Coat	1	4
↑↑↑↑ →↓↓↓ ↓↓↓	11	Redfish	2	6
↑↑↑↑ ↑↑→→ →↓	10	Ants	5	1
↑→→↓ ↓↓↓↓	8	England	7	5
↑↑↑↑ ↑←↓	7	Black	6	1
13↔ / 47↕	60			

Standing condition				
Gesture set for max path	#gestures for man path	Target item	Location of target item	
			Top level	Sub level
→→→→ ↓↓↓	7	Bats	5	3
↑↑↑← ←↓↓↓	8	Clarinet	3	3
↑↑↑← ↓↓	6	Cod	2	2
↑↑←↓ ↓↓↓↓	8	Dress	1	5
↑↑↑↑ ↑→→↓ ↓↓↓↓ ↓	13	Guitar	3	6
↑↑↑↑ ↑↑→→ →↓↓	11	Blue	6	2
↑↑→↓ ↓↓↓	7	Egypt	7	4
14↔ / 46↕	60			

Walking condition				
Gesture set for max path	#gestures for man path	Target item	Location of target item	
			Top level	Sub level
→↓↓↓	4	Eel	2	3
↑↑↑→	8	Apes	5	2
→→↓↓ ↑↑←← ↓↓↓↓ ↓	9	Flute	3	5
↑↑↑↑ ↑→↓↓	8	Cook	4	2
↑↑→→ →↓↓↓	8	Denmark	7	3
↑↑↑→ ↓↓↓↓ ↓↓↓	11	Lemon	8	7
↑↑↑↑ ↑↑↑← ←↓↓↓	12	Grey	6	3
13↔ / 47↕	60			

Training				
Gesture set for max path	#gestures for man path	Target item	Location of target item	
			Top level	Sub level
→→→↓ ↓↓↓	7	Driver	4	4
↑↑↑↑ →→→↓ ↓	9	China	7	2
↑↑←← ↓↓↓↓ ↓	10	Zebras	5	6
8↔ / 18↕	26			

Figure A.5: Sets of tasks used in the menu navigation study for: top-left - sitting condition; top-right - standing condition; bottom-left walking condition; bottom-right - training condition

Informed Consent Form

Evaluating "TextiPad" – a touchpad prototype made of fabrics

PRINCIPAL INVESTIGATOR Stefan Ivanov
Media Computing Group
RWTH Aachen University
Email: stefan.ivanov@rwth-aachen.de

Purpose of the study: The goal of this study is to evaluate a trousers prototype with a textile touchpad embedded in each leg for its usability and wearability. While wearing the prototype, participants will be presented different tasks that are to be completed through articulating gestures on the sensing surface. The individual touches, as well as details about the gestures, performed on the sensing areas, will be recorded and used in the analysis.

Procedure: Participation in this study will involve two phases. In the first phase while standing and wearing the prototype, you will be asked to perform a small number of gestures and the traces will be recorded as an image. In the second phase, you will be asked to perform gestures on the sensing surface in order to navigate to a particular item through a hierarchical menu that is two levels deep with exactly eight menu items per level. This phase will be repeated a few times under different circumstances i.e. sitting, standing and walking. After the study, we will ask you to fill out a questionnaire about the tested prototype. In this questionnaire, some general questions will be asked about your experience during the session and your habits and practices with respect to touch surface use.

Risks/Discomfort: You may become fatigued during the course of your participation in the study. You will be given opportunity to rest, and additional breaks are also possible. There are no other risks associated with participation in the study. Should completion of either the task or the questionnaire become distressing to you, do not hesitate to terminate it immediately.

Benefits: The results of this study will be useful for evaluating the usability and improving the prototype you are about to use.

Alternatives to Participation: Participation in this study is voluntary. You are free to withdraw or discontinue your participation.

Cost and Compensation: Participation in this study will involve no cost to you. There will be snacks and drinks for you during and after the participation.

Confidentiality: All information collected during the study period will be kept strictly confidential. You will be identified through identification numbers. Comments or answers to survey questions may be quoted in publications or reports from this project, but identifying information on any participant will not be included. If you agree to join this study, please sign your name below.

_____ I have read and understood the information on this form.

_____ I have had the information on this form explained to me.

Participant's Name:

Participant's Signature:

Date:

Principal Investigator:

Date:

If you have any questions regarding this study, please contact Stefan Ivanov by email: stefan.ivanov@rwth-aachen.de

Figure A.6: Informed consent form provided to participants prior to the start of the gestural menu navigation study

TextiPad evaluation questionnaire

Participant ID.....

1. I find the size of the sensing area of the prototype...
too small small appropriate big too big

2. I was able to clearly **see** the sensing surface borders.
fully disagree disagree neutral agree fully agree

3. I was able to clearly **feel** the sensing surface borders.
fully disagree disagree neutral agree fully agree

4. Compared to the rest of the prototype, I felt that the sensing area was...
very different different neutral similar very similar

5. The mapping of gestures to commands for navigating through the menu was...
very unintuitive unintuitive neutral intuitive very intuitive

6. I find performing the gestures to be...
very hard hard neutral easy very easy













7. If you have had any experience with touch based input devices before please rate its amount for the devices you have used (multiple answers possible).

	<u>none</u>	<u>little</u>	<u>some</u>	<u>much</u>	<u>very much</u>
• Touchpad					
• Mobile device with a touchscreen					
• Touch sensing table					
• Other (please write which ones below)					
.....					
.....					
.....					

Figure A.7: Questionnaire filled by participants in the end of the gestural menu navigation study

Appendix B

Detailed results from user studies

Gesture performed	User 1 RH		User 2 RH		User 3 RH		User 4 RH		User 5 LH		User 6 RH		Times done
	Stand	Sit	Stand	Sit	Stand	Sit	Stand	Sit	Stand	Sit	Stand	Sit	
 number					81 X 64	76 X 82							2
 circle	82 X 107	64 X 75	70 X 69	76 X 73	62 X 67	66 X 72					43 X 42	68 X 62	8
 arc					76 X 64	111 X 60							2
 triangle			62 X 81	54 X 76									2
 square			89 X 84	82 X 85					61 X 79	66 X 76	45 X 53	69 X 70	6
 check			81 X 77	100 X 91									2
 scribble							112 X 79	111 X 73					2
 X-cross											48 X 62	55 X 53	2
 cross	125 X 147												1
 zigzag	60 X 165	50 X 190											2
 smaller		66 X 129											1
 line		10 X 146											1
Mean value for user:	89 X 140	48 X 135	76 X 78	78 X 81	73 X 65	84 X 71	112 X 79	111 X 73	61 X 79	66 X 76	45 X 52	64 X 62	
Mean value for standing condition:			76 X 82				Mean value for sitting condition:				75 X 83		

*all sizes are in the following format: width X height [mm]

Figure B.1: Results from study on size and shape of the sensing area

Participant ID	Age	Sex	Thigh size	up-down mapping	left-right mapping	Highest completed degree	Current occupation	touchpad	touchscreen	touch table
US1P1	22	M	thin	yes	yes	High school	BSc Computer Science	5	5	2
Notes	<ul style="list-style-type: none"> Noise: while user was typing noise bounces were regularly observed in the center area; occasional noise occurred while user performed sit and stand, jumps and squats User articulated gestures very quickly 									
US1P2	24	F	thin	no	yes	BSc Automation	MSc Computer Science	5	5	2
Notes	<ul style="list-style-type: none"> Noise: while user was typing occasional noise bounces were observed in the center area; seldom noise bounces took place while user performed the sit and stand action and also while doing squats User articulated gestures quite fast 									
US1P3	24	M	moderate	yes	yes	BSc Computer Science	MSc Computer Science	5	4	3
Notes	<ul style="list-style-type: none"> Noise: noise bounces while user preparing for the typing and seldom noise in the center area while typing; occasional noise occurred while performing sit and stand action, walking, jogging, jumps and squats User articulated gestures by applying very little pressure on the prototype User noted that he performed all gestures in the center area and his finger was never in contact with the raised boundaries (he didn't feel them because he saw them and was aware of them) 									
US1P4	24	F	big	yes	yes	High school	BSc Applied Geography	4	3	1
Notes	<ul style="list-style-type: none"> Noise: noise had stable character and was situated in the center while typing; occasional noise bounces occurred while user performed sit and stand action, squats and walking Gesture articulation: horizontal and vertical lines seemed fine; checkmark got a few samples that seemed fine; circle and x gesture seemed bad overall with occasional patterns that were similar to the requested gesture 									
US1P5	28	M	moderate	no	yes	MSc Computer Science	Computer Science employee	5	5	5
Notes	<ul style="list-style-type: none"> Experience with multimedia screens – 5 Noise: noise bounces while user preparing for the typing and occasional noise in the central area while typing User touched the prototype once while filling the questionnaire Prototype texture was a bit rougher than standard jeans fabric for the user 									
US1P6	23	M	moderate	yes	yes	BSc Computer Science	MSc Computer Science	5	5	3
Notes	<ul style="list-style-type: none"> Experience with camera touchscreens – 4 Noise: noise bounces while user preparing for the typing and occasional noise in the central area while typing; occasional noise while sit and stand action around the center; single noise occurrence during walking again in the center User pointed out the raised border of the sensing area User touched the prototype while filling the questionnaire All users articulated the gestures quickly probably due to their previous experience with capacitive touchscreen devices. First three users did not press really hard while articulating gestures therefore the latter three were instructed to exercise larger amount of pressure while performing the gestures. However they still did not press really much probably afraid not to break the prototype. 									
General remarks										

Figure B.2: Results from proof of functionality study

Participant ID	I find the size of the sensing area of the prototype.	I was able to clearly see the sensing surface borders.	I was able to clearly feel the sensing surface borders.	How would you rate the feel of the prototype when using your finger compared to standard fabric?	I was able to feel the prototype as a whole with the skin of my thigh.	In case you were able to sense the prototype with the skin on your thigh, how would you classify the feeling?
US1P1	3	5	4	3	2	-
US1P2	3	4	5	2	1	-
US1P3	2	4	3	4	2	-
US1P4	2	4	5	4	4	3
US1P5	3	5	5	2	4	3
US1P6	3	5	5	5	4	2
-----	-----	-----	-----	-----	-----	-----
US2P1	3	5	4	5	3	-
US2P2	3	4	4	4	3	-
US2P3	3	5	5	5	3	-
US2P4	3	4	4	2	4	3
US2P5	3	4	4	2	3	-
US2P6	2	5	4	5	2	-
US2P7	3	2	3	1	3	-
US2P8	3	4	1	1	3	-
US2P9	2	5	5	5	4	3
US2P10	3	5	4	4	2	-
US2P11	3	3	4	4	1	-
US2P12	3	5	4	2	4	4
US2P13	3	2	2	4	4	3
US2P14	3	2	3	4	1	-
US2P15	3	4	4	5	3	-
US2P16	3	5	5	5	4	4
US2P17	2	5	5	2	1	-
US2P18	3	5	5	2	4	4
US2P19	3	4	4	5	2	-
US2P20	3	4	4	5	3	-
US2P21	3	4	2	5	4	3
US2P22	3	4	3	5	3	-
US2P23	3	5	5	5	4	4
US2P24	3	5	5	3	3	-
US2P25	3	4	5	2	2	-
US2P26	3	5	5	4	4	3

Figure B.3: First questionnaire responses: identifiers US1P1 - US1P6 proof of functionality participants, identifiers US2P1 - US2P26 target acquisition participants

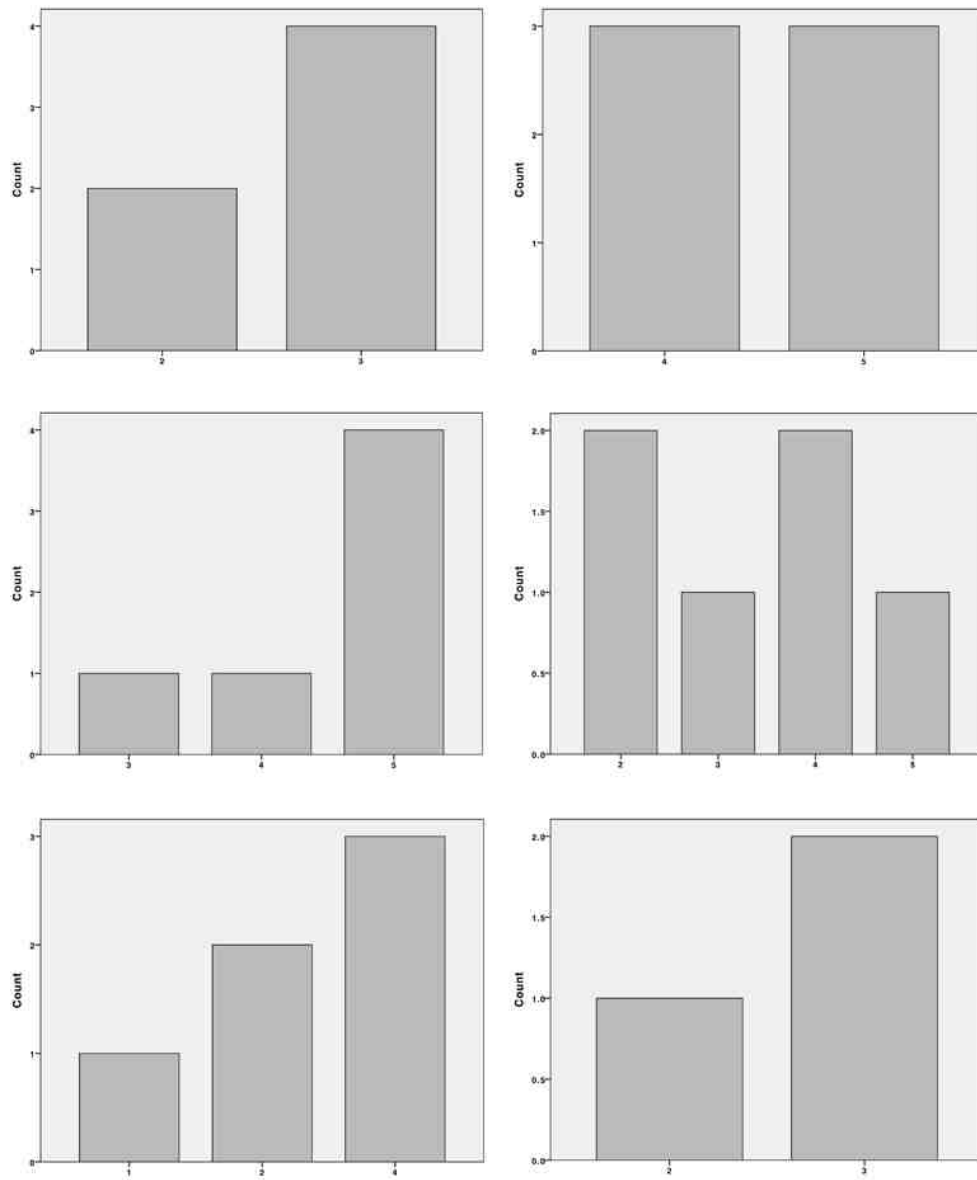

Figure B.4: Proof of functionality questionnaire graphs: top-left - size perception; top-right - visibility of sensing area borders; middle-left - tactility of sensing area borders; middle-right - tactility of sensing area compared to standard fabric; bottom-left - Perceive the sensor with the skin of the thigh; bottom-right - classification of the feeling in case sensor was perceived with the thigh

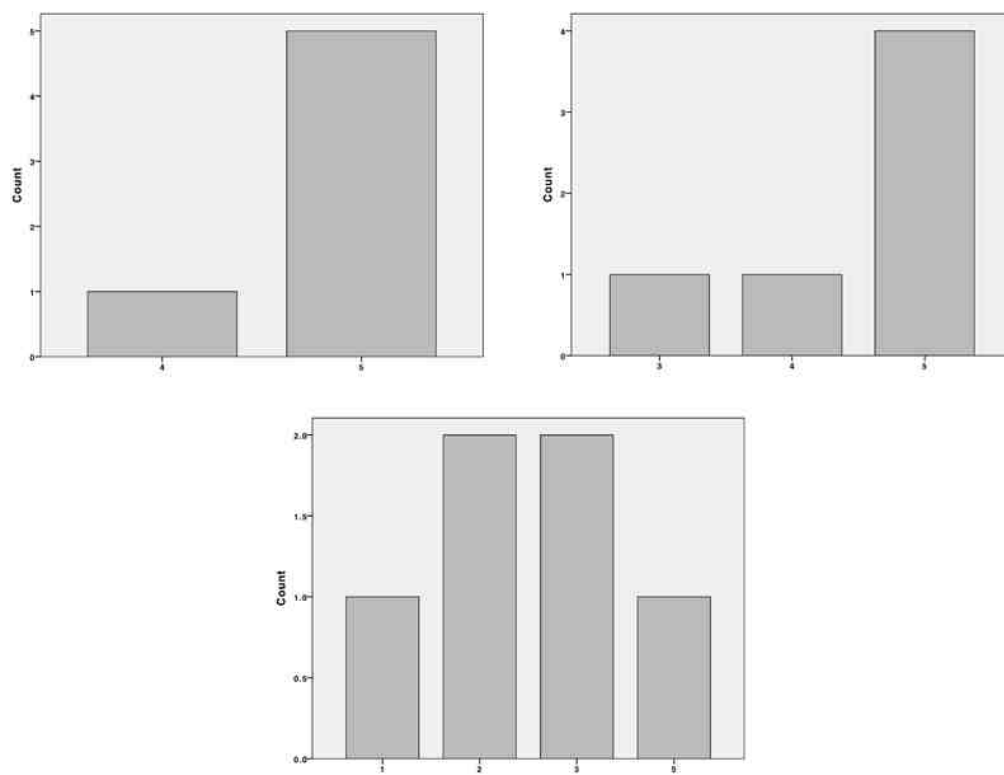

Figure B.5: Proof of functionality participants' experience graphs: top-left - with touchpad devices; top-right - with touchscreen devices; bottom - with touch-sensing tables

Participant ID	Sex	Edinburgh laterality index	Augmented laterality index	Hand used for articulation	Hand used for the game
US2P1	Male	6 th right	7 th right	Right	Right
US2P2	Female	10 th right	8 th right	Right	Right
US2P3	Male	3 rd left	1 st left	Left	Left
US2P4	Female	1 st right	1 st right	Right	Right
US2P5	Male	7 th right	8 th right	Right	Both
US2P6	Male	10 th right	8 th right	Right	Right
US2P7	Female	3 rd right	2 nd right	Right	Right
US2P8	Male	3 rd left	2 nd left	Left	Right
US2P9	Male	4 th right	3 rd right	Right	Right
US2P10	Male	3 rd right	3 rd right	Right	Right
US2P11	Male	5 th right	6 th right	Right	Right
US2P12	Male	5 th right	3 rd right	Right	Right
US2P13	Female	2 nd right	2 nd right	Right	Right
US2P14	Male	7 th right	5 th right	Right	Right
US2P15	Male	6 th right	4 th right	Right	Right
US2P16	Male	10 th left	7 th left	Right	Left
US2P17	Female	7 th right	6 th right	Left	Left
US2P18	Male	10 th right	10 th right	Right	Right
US2P19	Female	4 th right	5 th right	Right	Right
US2P20	Male	9 th right	9 th right	Right	Right
US2P21	Male	3 rd left	1 st left	Left	Left
US2P22	Male	4 th right	4 th right	Right	Right
US2P23	Female	10 th right	8 th right	Right	Right
US2P24	Male	6 th left	4 th left	Left	Left
US2P25	Female	6 th right	7 th right	Right	Right
US2P26	Male	middle	middle	Right	Right

Figure B.6: Table with laterality indices for participants' handedness for the target acquisition study

Summary of results				
Participant ID	Thigh-located prototype		Table-located prototype	
	Task completion time (seconds)	Initial landing error (mm)	Task completion time (seconds)	Initial landing error (mm)
US2P1	7.48	7.62	5.47	7.64
US2P2	31.39	17.42	11.95	10.72
US2P3	12.28	9.26	4.47	8.46
US2P4	13.12	13.36	9.06	11.22
US2P5	68.35	16.38	11.21	11.16
US2P6	11.62	9.31	6.90	7.53
US2P7	29.17	14.58	8.93	13.57
US2P8	11.43	11.91	6.81	10.82
US2P9	8.90	6.98	5.63	12.40
US2P10	9.24	8.10	9.62	9.38
US2P11	26.35	10.53	9.34	9.37
US2P12	23.07	8.66	13.61	7.31
US2P13	58.90	9.51	9.87	11.01
US2P14	17.33	9.26	7.18	11.00
US2P15	39.26	10.08	6.16	8.90
US2P16	33.61	12.58	5.73	9.42
US2P17	7.32	8.06	4.32	7.78
US2P18	11.40	7.74	4.72	7.54
US2P19	12.04	7.61	5.20	6.75
US2P20	15.42	6.41	4.85	6.79
US2P21	12.46	8.38	5.96	7.28
US2P22	14.29	8.94	6.43	7.98
US2P23	37.34	8.98	11.84	10.59
US2P24	11.91	6.81	9.56	8.96
US2P25	11.98	8.22	7.59	9.76
US2P26	11.20	8.00	9.10	7.90

Figure B.7: Summary of results extracted from the log files for target acquisition study

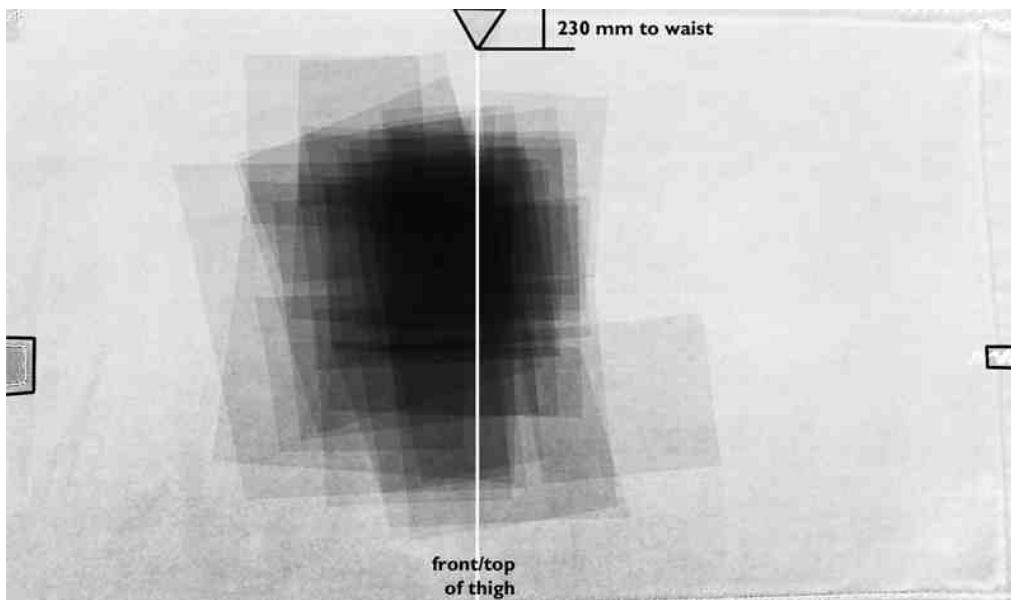

Figure B.8: Placement map for precisely locating sensor on the thigh

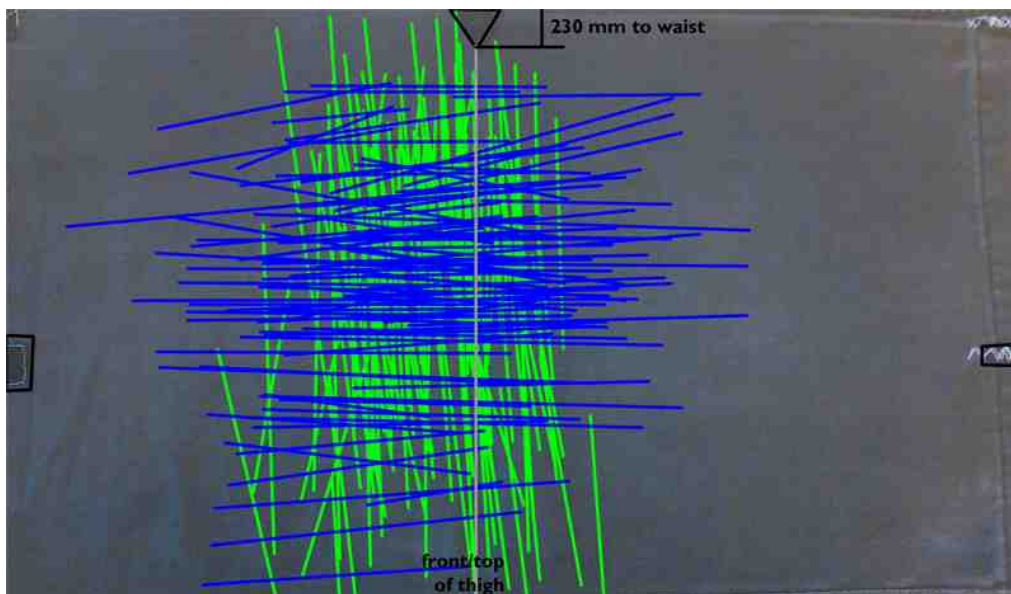

Figure B.9: Orientation map for precisely aligning the sensor with respect to the thigh

Descriptive Statistics					
	N	Mean	Std. Deviation	Minimum	Maximum
thigh	26	21.0331	15.76429	7.32	68.35
table	26	7.7504	2.60174	4.32	13.61

Wilcoxon Signed Ranks Test

Ranks				
		N	Mean Rank	Sum of Ranks
table - thigh	Negative Ranks	25 ^a	14.00	350.00
	Positive Ranks	1 ^b	1.00	1.00
	Ties	0 ^c		
	Total	26		

a. table < thigh
b. table > thigh
c. table = thigh

Test Statistics ^{b,c}					
					table - thigh
Z					-4.432 ^a
Asymp. Sig. (2-tailed)					.000
Monte Carlo Sig. (2-tailed)	Sig.				.000
	99% Confidence Interval	Lower Bound			.000
		Upper Bound			.162
Monte Carlo Sig. (1-tailed)	Sig.				.000
	99% Confidence Interval	Lower Bound			.000
		Upper Bound			.162

a. Based on positive ranks.
b. Wilcoxon Signed Ranks Test
c. Based on 26 sampled tables with starting seed 926214481.

Figure B.10: Detailed statistical results about task completion time for target acquisition study

Descriptive Statistics

	N	Mean	Std. Deviation	Minimum	Maximum
thigh	26	12.2446	3.61632	8.01	21.77
table	26	11.5981	2.28790	8.44	16.96

Wilcoxon Signed Ranks Test

Ranks

		N	Mean Rank	Sum of Ranks
table - thigh	Negative Ranks	17 ^a	12.59	214.00
	Positive Ranks	9 ^b	15.22	137.00
	Ties	0 ^c		
	Total	26		

- a. table < thigh
b. table > thigh
c. table = thigh

Test Statistics^{b,c}

				table - thigh
Z				-.978 ^a
Asymp. Sig. (2-tailed)				.328
Monte Carlo Sig. (2-tailed)	Sig.			.231
		99% Confidence Interval	Lower Bound	.018
			Upper Bound	.444
Monte Carlo Sig. (1-tailed)	Sig.			.038
		99% Confidence Interval	Lower Bound	.000
			Upper Bound	.136

- a. Based on positive ranks.
b. Wilcoxon Signed Ranks Test
c. Based on 26 sampled tables with starting seed 2000000.

Figure B.11: Detailed statistical results about initial pointing error for target acquisition study

Participant ID	Sex	Edinburgh laterality index	Augmented laterality index	Hand used for articulation
US3P1	Male	6 th right	6 th right	Right
US3P2	Male	10 th left	10 th left	Left
US3P3	Male	10 th right	10 th right	Right
US3P4	Male	5 th right	5 th right	Right
US3P5	Male	1 st right	2 nd right	Right
US3P7	Male	7 th right	6 th right	Right
US3P8	Male	4 th right	3 rd right	Right
US3P9	Male	2 nd right	3 rd right	Right
US3P10	Female	7 th right	7 th right	Right
US3P11	Female	6 th right	5 th right	Right
US3P12	Male	3 rd left	1 st left	Right
US3P13	Male	1 st right	1 st right	Left
US3P14	Male	10 th right	7 th right	Right
US3P15	Female	3 rd right	2 nd right	Right
US3P16	Male	10 th right	9 th right	Right
US3P17	Male	5 th right	6 th right	Right
US3P18	Male	6 th left	4 th left	Left

Figure B.12: Table with laterality indices for participants' handedness for the menu navigation study (US3P6 results declared invalid)

Results subject to statistical analysis:

Participant	Recognized gestures duration (seconds)			Not recognized gestures duration (seconds)			All gestures duration (seconds)		
	Sitting	Standing	Walking	Sitting	Standing	Walking	Sitting	Standing	Walking
US3P1	2,25	1,74	1,75	1,48	1,30	1,39	1,95	1,54	1,52
US3P2	2,33	1,52	1,42	1,56	1,51	1,16	2,16	1,52	1,28
US3P3	2,09	2,49	1,69	1,13	1,42	1,16	1,84	2,07	1,40
US3P4	2,38	2,38	1,63	1,46	1,40	1,24	1,87	1,85	1,41
US3P5	1,59	1,92	1,71	1,64	1,72	1,13	1,57	1,84	1,34
US3P7	2,27	1,83	1,43	1,79	1,44	1,21	2,00	1,68	1,28
US3P8	1,80	1,68	1,91	1,39	1,31	1,18	1,55	1,47	1,48
US3P9	2,07	2,12	1,77	1,36	1,19	1,23	1,78	1,79	1,40
US3P10	2,90	2,87	2,48	2,23	1,73	1,50	2,64	2,70	2,19
US3P11	1,89	1,55	1,81	1,35	1,13	1,28	1,63	1,36	1,62
US3P12	1,49	1,71	1,68	1,13	1,12	1,38	1,38	1,39	1,52
US3P13	1,52	2,31	1,50	1,05	1,82	1,11	1,32	1,90	1,29
US3P14	1,94	2,39	1,76	1,22	1,55	1,36	1,63	2,06	1,59
US3P15	1,66	1,71	1,65	1,29	1,29	1,38	1,43	1,51	1,48
US3P16	1,77	1,91	1,75	1,30	1,44	1,46	1,62	1,70	1,59
US3P17	1,73	1,80	1,85	1,35	1,02	1,14	1,66	1,63	1,53
US3P18	2,03	1,88	1,80	1,76	1,68	1,51	1,94	1,80	1,69

Participant	Recognition rate (%)			Number of gestures in the set to complete condition			Total number of gestures to complete condition		
	Sitting	Standing	Walking	Sitting	Standing	Walking	Sitting	Standing	Walking
US3P1	0,53	0,49	0,34	63	70	65	118	144	190
US3P2	0,63	0,50	0,45	81	62	69	129	124	152
US3P3	0,64	0,42	0,44	62	70	65	97	167	147
US3P4	0,44	0,47	0,39	67	70	60	154	149	155
US3P5	0,91	0,79	0,39	64	67	61	70	85	155
US3P7	0,45	0,54	0,34	77	65	-	171	121	-
US3P8	0,37	0,40	0,41	-	-	77	-	-	190
US3P9	0,62	0,51	0,30	63	-	-	101	-	-
US3P10	0,76	0,82	0,69	61	65	75	80	79	109
US3P11	0,48	0,55	0,63	67	62	67	140	113	107
US3P12	0,58	0,44	0,48	68	60	70	117	136	147
US3P13	0,56	0,59	0,46	64	77	68	115	130	148
US3P14	0,57	0,55	0,58	71	74	64	125	135	110
US3P15	0,37	0,50	0,39	65	65	64	174	131	162
US3P16	0,67	0,53	0,40	64	72	63	96	137	158
US3P17	0,78	0,67	0,56	62	62	64	80	92	115
US3P18	0,65	0,59	0,60	62	81	78	96	138	131

Figure B.13: Summary of results extracted from the log files for menu navigation study

Descriptive Statistics

	N	Percentiles		
		25th	50th (Median)	75th
sitting	17	1.5600	1.6600	1.9450
standing	17	1.5150	1.7000	1.8750
walking	17	1.3700	1.4800	1.5900

Friedman Test

Ranks

	Mean Rank
sitting	2.35
standing	2.35
walking	1.29

Test Statistics^a

N	17
Chi-Square	12.706
df	2
Asymp. Sig.	.002

a. Friedman Test

Descriptive Statistics

	N	Mean	Std. Deviation	Minimum	Maximum	Percentiles		
						25th	50th (Median)	75th
sitting	17	1.7629	.32305	1.32	2.64	1.5600	1.6600	1.9450
standing	17	1.7535	.32423	1.36	2.70	1.5150	1.7000	1.8750
walking	17	1.5065	.21494	1.28	2.19	1.3700	1.4800	1.5900

Wilcoxon Signed Ranks Test

Ranks

		N	Mean Rank	Sum of Ranks
standing - sitting	Negative Ranks	8 ^a	9.81	78.50
	Positive Ranks	9 ^b	8.28	74.50
	Ties	0 ^c		
	Total	17		
walking - sitting	Negative Ranks	15 ^d	9.33	140.00
	Positive Ranks	2 ^e	6.50	13.00
	Ties	0 ^f		
	Total	17		
walking - standing	Negative Ranks	14 ^g	9.71	136.00
	Positive Ranks	3 ^h	5.67	17.00
	Ties	0 ⁱ		
	Total	17		

a. standing < sitting
 b. standing > sitting
 c. standing = sitting
 d. walking < sitting
 e. walking > sitting
 f. walking = sitting
 g. walking < standing
 h. walking > standing
 i. walking = standing

Test Statistics^b

	standing - sitting	walking - sitting	walking - standing
Z	-.095 ^a	-3.006 ^a	-2.817 ^a
Asymp. Sig. (2-tailed)	.925	.003	.005

a. Based on positive ranks.
 b. Wilcoxon Signed Ranks Test

Figure B.14: Detailed statistical results about average gesture duration for menu navigation study

	N	Percentiles		
		25th	50th (Median)	75th
sitting	17	1.6950	1.9400	2.2600
standing	17	1.7100	1.8800	2.3450
walking	17	1.6400	1.7500	1.8050

Friedman Test

	Mean Rank
sitting	2.21
standing	2.32
walking	1.47

N	17
Chi-Square	7.373
df	2
Asymp. Sig.	.025

a. Friedman Test

	N	Mean	Std. Deviation	Minimum	Maximum	Percentiles		
						25th	50th (Median)	75th
sitting	17	1.9829	.36771	1.49	2.90	1.6950	1.9400	2.2600
standing	17	1.9888	.37673	1.52	2.87	1.7100	1.8800	2.3450
walking	17	1.7406	.23477	1.42	2.48	1.6400	1.7500	1.8050

Wilcoxon Signed Ranks Test

	N	Mean Rank	Sum of Ranks
standing - sitting	Negative Ranks	7 ^a	65.00
	Positive Ranks	9 ^b	71.00
	Ties	1 ^c	
	Total	17	
walking - sitting	Negative Ranks	13 ^d	126.00
	Positive Ranks	4 ^e	27.00
	Ties	0 ^f	
	Total	17	
walking - standing	Negative Ranks	13 ^d	130.00
	Positive Ranks	4 ^h	23.00
	Ties	0 ⁱ	
	Total	17	

a. standing < sitting
b. standing > sitting
c. standing = sitting
d. walking < sitting
e. walking > sitting
f. walking = sitting
g. walking < standing
h. walking > standing
i. walking = standing

	standing - sitting	walking - sitting	walking - standing
Z	-.155 ^a	-2.344 ^b	-2.533 ^b
Asymp. Sig. (2-tailed)	.877	.019	.011

a. Based on negative ranks.
b. Based on positive ranks.
c. Wilcoxon Signed Ranks Test

Figure B.15: Detailed statistical results about average recognized gesture duration for menu navigation study

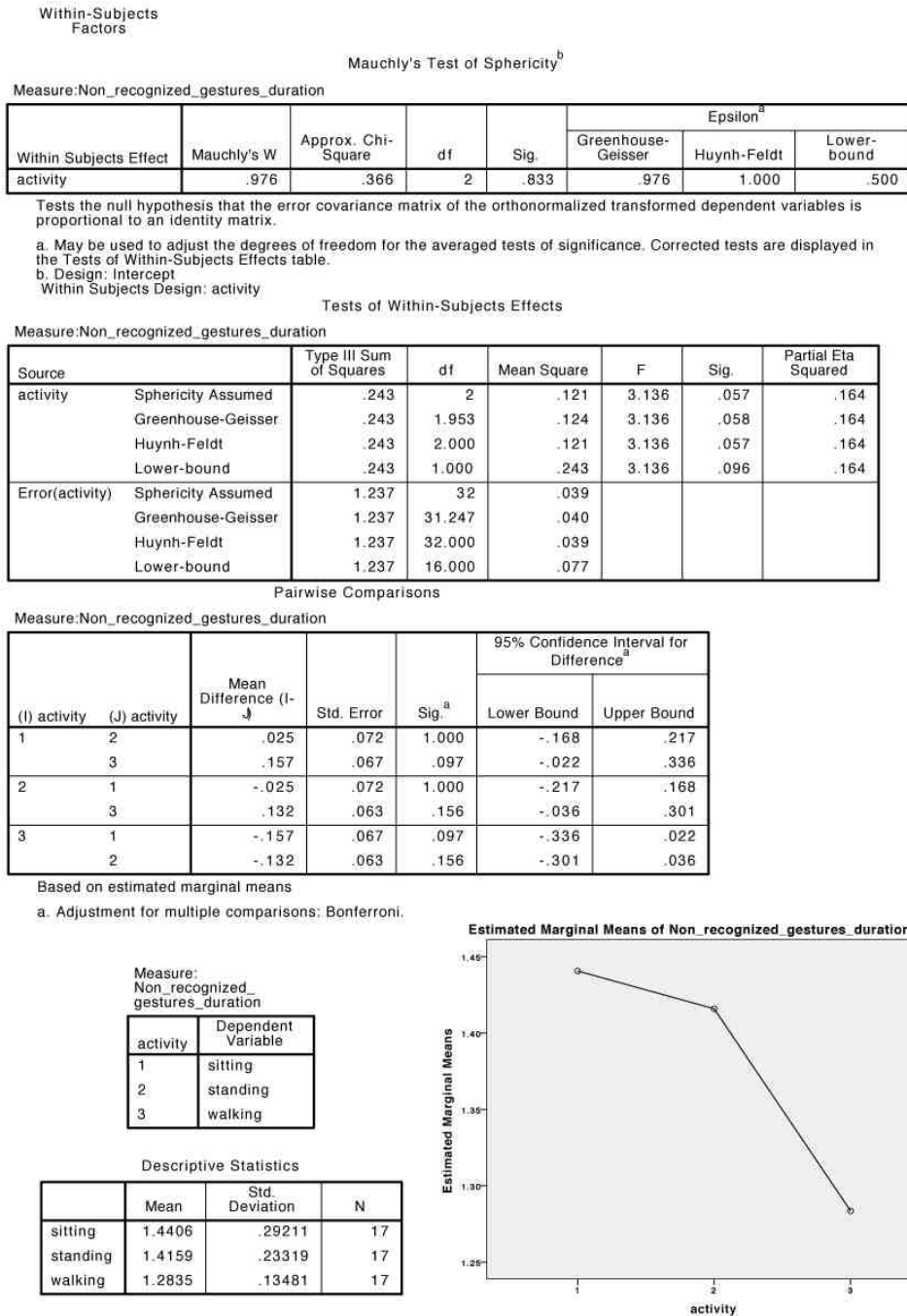

Figure B.16: Detailed statistical results about average not recognized gesture duration for menu navigation study

Within-Subjects Factors

Mauchly's Test of Sphericity^b

Measure: Recognition_rate

Within Subjects Effect	Mauchly's W	Approx. Chi-Square	df	Sig.	Epsilon ^a		
					Greenhouse-Geisser	Huynh-Feldt	Lower-bound
activity	.762	4.076	2	.130	.808	.885	.500

Tests the null hypothesis that the error covariance matrix of the orthonormalized transformed dependent variables is proportional to an identity matrix.

a. May be used to adjust the degrees of freedom for the averaged tests of significance. Corrected tests are displayed in the Tests of Within-Subjects Effects table.

b. Design: Intercept
Within Subjects Design: activity

Tests of Within-Subjects Effects

Measure: Recognition_rate

Source		Type III Sum of Squares	df	Mean Square	F	Sig.	Partial Eta Squared
activity	Sphericity Assumed	.538	2	.269	9.170	.001	.364
	Greenhouse-Geisser	.538	1.616	.333	9.170	.002	.364
	Huynh-Feldt	.538	1.770	.304	9.170	.001	.364
	Lower-bound	.538	1.000	.538	9.170	.008	.364
Error(activity)	Sphericity Assumed	.940	32	.029			
	Greenhouse-Geisser	.940	25.850	.036			
	Huynh-Feldt	.940	28.326	.033			
	Lower-bound	.940	16.000	.059			

Pairwise Comparisons

Measure: Recognition_rate

(I) activity	(J) activity	Mean Difference (I-J)	Std. Error	Sig. ^a	95% Confidence Interval for Difference ^a	
					Lower Bound	Upper Bound
1	2	.057	.046	.685	-.065	.179
	3	.241	.071	.011	.052	.430
2	1	-.057	.046	.685	-.179	.065
	3	.184	.057	.017	.030	.337
3	1	-.241	.071	.011	-.430	-.052
	2	-.184	.057	.017	-.337	-.030

Based on estimated marginal means

a. Adjustment for multiple comparisons: Bonferroni.
*. The mean difference is significant at the

Measure: Recognition_rate

activity	Dependent Variable
1	sitting
2	standing
3	walking

Descriptive Statistics

	Mean	Std. Deviation	N
sitting	-.5587	.25068	17
standing	-.6158	.19709	17
walking	-.7996	.23738	17

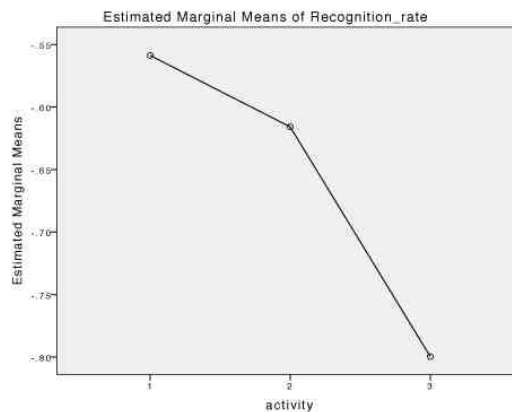

Figure B.17: Detailed statistical results about recognition rate for menu navigation study

Descriptive Statistics

	N	Percentiles		
		25th	50th (Median)	75th
sitting	14	62.0000	64.0000	67.2500
standing	14	62.0000	68.5000	72.5000
walking	14	63.7500	65.0000	69.2500

Friedman Test

Ranks

	Mean Rank
sitting	1.75
standing	2.36
walking	1.89

Test Statistics^a

N	14
Chi-Square	2.981
df	2
Asymp. Sig.	.225

a. Friedman Test

Figure B.18: Detailed statistical results about the amount of recognized gestures for menu navigation study

Within-Subjects Factors

Mauchly's Test of Sphericity^b

Measure: Number_of_identified_gestures

Within Subjects Effect	Mauchly's W	Approx. Chi-Square	df	Sig.	Epsilon ^a		
					Greenhouse-Geisser	Huynh-Feldt	Lower-bound
activity	.894	1.348	2	.510	.904	1.000	.500

Tests the null hypothesis that the error covariance matrix of the orthonormalized transformed dependent variables is proportional to an identity matrix.

a. May be used to adjust the degrees of freedom for the averaged tests of significance. Corrected tests are displayed in the Tests of Within-Subjects Effects table.

b. Design: Intercept
Within Subjects Design: activity

Tests of Within-Subjects Effects

Measure: Number_of_identified_gestures

Source		Type III Sum of Squares	df	Mean Square	F	Sig.	Partial Eta Squared
activity	Sphericity Assumed	5611.000	2	2805.500	6.414	.005	.330
	Greenhouse-Geisser	5611.000	1.808	3103.604	6.414	.007	.330
	Huynh-Feldt	5611.000	2.000	2805.500	6.414	.005	.330
	Lower-bound	5611.000	1.000	5611.000	6.414	.025	.330
Error(activity)	Sphericity Assumed	11371.667	26	437.372			
	Greenhouse-Geisser	11371.667	23.503	483.846			
	Huynh-Feldt	11371.667	26.000	437.372			
	Lower-bound	11371.667	13.000	874.744			

Pairwise Comparisons

Measure: Number_of_identified_gestures

(I) activity	(J) activity	Mean Difference (I-J)	Std. Error	Sig. ^a	95% Confidence Interval for Difference ^a	
					Lower Bound	Upper Bound
1	2	-12.071	7.655	.416	-33.091	8.949
	3	-28.214	9.041	.024	-53.040	-3.388
2	1	12.071	7.655	.416	-8.949	33.091
	3	-16.143	6.864	.105	-34.990	2.704
3	1	28.214	9.041	.024	3.388	53.040
	2	16.143	6.864	.105	-2.704	34.990

Based on estimated marginal means

a. Adjustment for multiple comparisons: Bonferroni.
*. The mean difference is significant at the

Measure: Number_of_identified_gestures

activity	Dependent Variable
1	sitting
2	standing
3	walking

Descriptive Statistics

	Mean	Std. Deviation	N
sitting	113.6429	29.65340	14
standing	125.7143	25.17456	14
walking	141.8571	24.29263	14

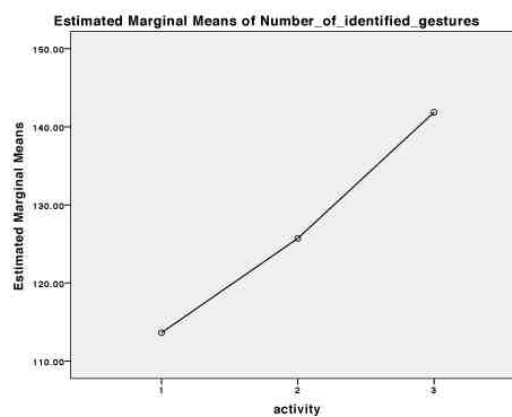

Figure B.19: Detailed statistical results about the amount of identified gestures for menu navigation study

Participant ID	I find the size of the sensing area of the prototype ...	I was able to clearly see the sensing surface borders.	I was able to clearly feel the sensing surface borders.	Compared to the rest of the prototype, I felt that the sensing area was ...	The mapping of gestures to commands for navigating through the menu was ...	I find performing the gestures to be ...
US3P1	3	4	3	(1)	5	1
US3P2	3	5	4	5	5	1
US3P3	3	5	4	4	4	4
US3P4	2	5	4	4	4	2
US3P5	3	5	4	3	4	2
US3P7	3	1	2	5	5	2
US3P8	2	4	3	4	5	2
US3P9	2	4	3	2	4	3
US3P10	3	4	3	4	4	4
US3P11	3	4	4	3	2	2
US3P12	3	4	4	3	4	2
US3P13	3	5	4	4	1	1
US3P14	3	4	4	4	4	3
US3P15	3	5	5	4	4	3
US3P16	3	5	3	4	4	2
US3P17	3	5	5	2	5	2
US3P18	3	5	4	4	5	3

Figure B.20: Second questionnaire replies

Appendix C

Optimization results

Duration spacing – spacing from previous gesture in seconds.

Overlap spacing – spacing of the overlapping with the previous gesture.

Participant ID	Duration spacing = 0,50 Overlap spacing = 35			Duration spacing = 0,67 Distance spacing = 35		
	sitting	standing	walking	sitting	standing	walking
US3P1	2	5	0	3	5	0
US3P2	3	3	3	5	3	4
US3P3	2	18	15	4	20	16
US3P4	6	3	15	6	7	16
US3P5	1	0	7	1	0	8
US3P7	2	4	3	3	5	3
US3P8	4	4	2	10	10	2
US3P9	4	12	4	4	19	10
US3P10	1	0	5	1	0	6
US3P11	4	2	1	4	2	2
US3P12	0	6	1	1	8	2
US3P13	3	5	2	4	6	2
US3P14	2	2	1	2	3	2
US3P15	6	6	4	6	6	4
US3P16	3	4	3	4	7	3
US3P17	0	3	4	0	6	5
US3P18	0	1	0	0	1	1

Recognition rate comparison (%)									
Participant	Original			Duration spacing = 0,50 Overlap spacing = 35			Duration spacing = 0,67 Overlap spacing = 35		
	Sitting	Standing	Walking	Sitting	Standing	Walking	Sitting	Standing	Walking
US3P1	0,53	0,49	0,34	0,56	0,54	0,34	0,57	0,54	0,34
US3P2	0,63	0,50	0,45	0,67	0,54	0,48	0,69	0,54	0,49
US3P3	0,64	0,42	0,44	0,67	0,59	0,61	0,71	0,61	0,62
US3P4	0,44	0,47	0,39	0,49	0,50	0,54	0,49	0,54	0,55
US3P5	0,91	0,79	0,39	0,94	0,79	0,46	0,94	0,79	0,47
US3P7	0,45	0,54	0,34	0,47	0,59	-	0,48	0,60	-
US3P8	0,37	0,40	0,41	-	-	0,42	-	-	0,42
US3P9	0,62	0,51	0,30	0,69	-	-	0,69	-	-
US3P10	0,76	0,82	0,69	0,78	0,82	0,77	0,78	0,82	0,79
US3P11	0,48	0,55	0,63	0,52	0,58	0,64	0,52	0,58	0,66
US3P12	0,58	0,44	0,48	0,58	0,51	0,49	0,59	0,53	0,50
US3P13	0,56	0,59	0,46	0,60	0,66	0,48	0,61	0,67	0,48
US3P14	0,57	0,55	0,58	0,59	0,57	0,60	0,59	0,58	0,61
US3P15	0,37	0,50	0,39	0,42	0,57	0,43	0,42	0,57	0,43
US3P16	0,67	0,53	0,40	0,72	0,57	0,43	0,74	0,61	0,43
US3P17	0,78	0,67	0,56	0,78	0,73	0,61	0,78	0,79	0,63
US3P18	0,65	0,59	0,60	0,65	0,60	0,60	0,65	0,60	0,61

Figure C.1: Optimization results: top - number of gestures merged; bottom - recognition rate improvement

Bibliography

Lisa Anthony and Jacob O. Wobbrock. A lightweight multistroke recognizer for user interface prototypes. In *Proceedings of Graphics Interface 2010, GI '10*, pages 245–252, Toronto, Ont., Canada, Canada, 2010. Canadian Information Processing Society. ISBN 978-1-56881-712-5. URL <http://dl.acm.org/citation.cfm?id=1839214.1839258>.

Stephen Brewster, Joanna Lumsden, Marek Bell, Malcolm Hall, and Stuart Tasker. Multimodal 'eyes-free' interaction techniques for wearable devices. In *Proceedings of the SIGCHI conference on Human factors in computing systems, CHI '03*, pages 473–480, New York, NY, USA, 2003. ACM. ISBN 1-58113-630-7. doi: 10.1145/642611.642694. URL <http://doi.acm.org/10.1145/642611.642694>.

L. Buechley. A construction kit for electronic textiles. In *Wearable Computers, 2006 10th IEEE International Symposium on*, pages 83–90, oct. 2006. doi: 10.1109/ISWC.2006.286348.

S.K. Card, T.P. Moran, and A. Newell. The model human processor. In *Handbook of perception and human performance*, volume 1, pages 1–35, 1986.

Stuart K. Card, Jock D. Mackinlay, and George G. Robertson. The design space of input devices. In *Proceedings of the SIGCHI conference on Human factors in computing systems: Empowering people, CHI '90*, pages 117–124, New York, NY, USA, 1990. ACM. ISBN 0-201-50932-6. doi: 10.1145/97243.97263. URL <http://doi.acm.org/10.1145/97243.97263>.

Géry Casiez, Nicolas Roussel, and Daniel Vogel. A simple speed-based low-pass filter for noisy in-

put in interactive systems. In *Proceedings of the 2012 ACM annual conference on Human Factors in Computing Systems, CHI '12*, pages 2527–2530, New York, NY, USA, 2012. ACM. ISBN 978-1-4503-1015-4. doi: 10.1145/2208636.2208639. URL <http://doi.acm.org/10.1145/2208636.2208639>.

Jingyuan Cheng, David Bannach, Kurt Adamer, Thomas Bernreiter, and Paul Lukowicz. A wearable, conductive textile based user interface for hospital ward rounds document access. In *Proceedings of the 3rd European Conference on Smart Sensing and Context, EuroSSC '08*, pages 182–191, Berlin, Heidelberg, 2008. Springer-Verlag. ISBN 978-3-540-88792-8. doi: 10.1007/978-3-540-88793-5_14. URL http://dx.doi.org/10.1007/978-3-540-88793-5_14.

Jonny Farrington, Andrew J. Moore, Nancy Tilbury, James Church, and Pieter D. Biemond. Wearable sensor badge and sensor jacket for context awareness. In *Proceedings of the 3rd IEEE International Symposium on Wearable Computers, ISWC '99*, pages 107–, Washington, DC, USA, 1999. IEEE Computer Society. ISBN 0-7695-0428-0. URL <http://dl.acm.org/citation.cfm?id=519309.856485>.

F. Gemperle, C. Kasabach, J. Stivoric, M. Bauer, and R. Martin. Design for wearability. In *Proceedings of the 2nd IEEE International Symposium on Wearable Computers, ISWC '98*, pages 116–, Washington, DC, USA, 1998. IEEE Computer Society. ISBN 0-8186-9074-7. URL <http://dl.acm.org/citation.cfm?id=857199.857998>.

S. Gilliland, N. Komor, T. Starner, and C. Zeagler. The textile interface swatchbook: Creating graphical user interface-like widgets with conductive embroidery. In *Wearable Computers (ISWC), 2010 International Symposium on*, pages 1 –8, oct. 2010. doi: 10.1109/ISWC.2010.5665876.

Paul Holleis, Albrecht Schmidt, Susanna Paasovaara, Arto Puikkonen, and Jonna Häkkinä. Evaluating capacitive touch input on clothes. In *Proceedings of the 10th international conference on Human computer interaction with mobile devices and services, MobileHCI '08*, pages 81–90, New York, NY, USA, 2008. ACM. ISBN 978-1-59593-952-4.

- doi: 10.1145/1409240.1409250. URL <http://doi.acm.org/10.1145/1409240.1409250>.
- R. Hurford, A. Martin, and P. Larsen. Designing wearables. In *Wearable Computers, 2006 10th IEEE International Symposium on*, pages 133–134, oct. 2006. doi: 10.1109/ISWC.2006.286362.
- Hesham M. Kamel and James A. Landay. Sketching images eyes-free: a grid-based dynamic drawing tool for the blind. In *Proceedings of the fifth international ACM conference on Assistive technologies, Assets '02*, pages 33–40, New York, NY, USA, 2002. ACM. ISBN 1-58113-464-9. doi: 10.1145/638249.638258. URL <http://doi.acm.org/10.1145/638249.638258>.
- Thorsten Karrer, Moritz Wittenhagen, Leonhard Lichtschlag, Florian Heller, and Jan Borchers. Pinstripe: Eyes-free continuous input on interactive clothing. In *Proceedings of the CHI 2011 Conference on Human Factors in Computing Systems*, Vancouver, Canada, May 2011. ACM Press.
- Nicholas Komor, Scott Gilliland, James Clawson, Manish Bhardwaj, Mayank Garg, Clint Zeagler, and Thad Starner. Is it gropable? - assessing the impact of mobility on textile interfaces. In *Proceedings of the 2009 International Symposium on Wearable Computers, ISWC '09*, pages 71–74, Washington, DC, USA, 2009. IEEE Computer Society. ISBN 978-0-7695-3779-5. doi: 10.1109/ISWC.2009.21. URL <http://dx.doi.org/10.1109/ISWC.2009.21>.
- Kevin A. Li. Designing easily learnable eyes-free interaction, 2008.
- Torsten Linz, Christine Kallmayer, Rolf Aschenbrenner, and Herbert Reichl. Embroidering electrical interconnects with conductive yarn for the integration of flexible electronic modules into fabric. In *Proceedings of the Ninth IEEE International Symposium on Wearable Computers, ISWC '05*, pages 86–91, Washington, DC, USA, 2005. IEEE Computer Society. ISBN 0-7695-2419-2. doi: 10.1109/ISWC.2005.19. URL <http://dx.doi.org/10.1109/ISWC.2005.19>.

- G. Loriga, N. Taccini, D. De Rossi, and R. Paradiso. Textile sensing interfaces for cardiopulmonary signs monitoring. In *Engineering in Medicine and Biology Society, 2005. IEEE-EMBS 2005. 27th Annual International Conference of the*, pages 7349–7352, jan. 2005. doi: 10.1109/IEMBS.2005.1616209.
- Steve Mann. Smart clothing: The wearable computer and wearcam. *Personal Technologies*, 1(1):21–27, 1997. doi: 10.1007/BF01317885. URL <http://dx.doi.org/10.1007/BF01317885>.
- D. Marculescu, R. Marculescu, N.H. Zamora, P. Stanley-Marbell, P.K. Khosla, S. Park, S. Jayaraman, S. Jung, C. Lauterbach, W. Weber, T. Kirstein, D. Cottet, J. Grzyb, G. Troster, M. Jones, T. Martin, and Z. Nakad. Electronic textiles: A platform for pervasive computing. *Proceedings of the IEEE*, 91(12):1995–2018, dec 2003. ISSN 0018-9219. doi: 10.1109/JPROC.2003.819612.
- J. McCann, R. Hurford, and A. Martin. A design process for the development of innovative smart clothing that addresses end-user needs from technical, functional, aesthetic and cultural view points. In *Wearable Computers, 2005. Proceedings. Ninth IEEE International Symposium on*, pages 70–77, oct. 2005. doi: 10.1109/ISWC.2005.3.
- Ian Oakley and Jun-Seok Park. Designing eyes-free interaction. In *Proceedings of the 2nd international conference on Haptic and audio interaction design, HAID'07*, pages 121–132, Berlin, Heidelberg, 2007. Springer-Verlag. ISBN 3-540-76701-0, 978-3-540-76701-5. URL <http://dl.acm.org/citation.cfm?id=1775512.1775530>.
- R. C. Oldfield. The assessment and analysis of handedness: The Edinburgh inventory. *Neuropsychologia*, 9:97–113, 1971. doi: 10.1016/0028-3932(71)90067-4.
- Maggie Orth, Rehmi Post, and Emily Cooper. Fabric computing interfaces. In *CHI 98 conference summary on Human factors in computing systems, CHI '98*, pages 331–332, New York, NY, USA, 1998. ACM. ISBN 1-58113-028-7. doi: 10.1145/286498.286800. URL <http://doi.acm.org/10.1145/286498.286800>.
- Hannah Perner-Wilson, Leah Buechley, and Mika Satomi. Handcrafting textile interfaces from a kit-of-no-parts. In

- Proceedings of the fifth international conference on Tangible, embedded, and embodied interaction, TEI '11*, pages 61–68, New York, NY, USA, 2011. ACM. ISBN 978-1-4503-0478-8. doi: 10.1145/1935701.1935715. URL <http://doi.acm.org/10.1145/1935701.1935715>.
- Antti Pirhonen, Stephen Brewster, and Christopher Holguin. Gestural and audio metaphors as a means of control for mobile devices. In *Proceedings of the SIGCHI conference on Human factors in computing systems: Changing our world, changing ourselves, CHI '02*, pages 291–298, New York, NY, USA, 2002. ACM. ISBN 1-58113-453-3. doi: 10.1145/503376.503428. URL <http://doi.acm.org/10.1145/503376.503428>.
- E. R. Post, M. Orth, P. R. Russo, and N. Gershenfeld. E-broidery: design and fabrication of textile-based computing. *IBM Syst. J.*, 39(3-4):840–860, July 2000. ISSN 0018-8670. doi: 10.1147/sj.393.0840. URL <http://dx.doi.org/10.1147/sj.393.0840>.
- J. Rantanen, J. Impiö, T. Karinsalo, M. Malmivaara, A. Reho, M. Tasanen, and J. Vanhala. Smart clothing prototype for the arctic environment. *Personal Ubiquitous Comput.*, 6(1):3–16, January 2002. ISSN 1617-4909. doi: 10.1007/s007790200001. URL <http://dx.doi.org/10.1007/s007790200001>.
- T. Scott Saponas, Chris Harrison, and Hrvoje Benko. Pock-ettouch: through-fabric capacitive touch input. In *Proceedings of the 24th annual ACM symposium on User interface software and technology, UIST '11*, pages 303–308, New York, NY, USA, 2011. ACM. ISBN 978-1-4503-0716-1. doi: 10.1145/2047196.2047235. URL <http://doi.acm.org/10.1145/2047196.2047235>.
- Nitin Sawhney and Chris Schmandt. Nomadic radio: speech and audio interaction for contextual messaging in nomadic environments. *ACM Trans. Comput.-Hum. Interact.*, 7(3):353–383, September 2000. ISSN 1073-0516. doi: 10.1145/355324.355327. URL <http://doi.acm.org/10.1145/355324.355327>.
- T. Schiphorst, N. Jaffe, and R. Lovell. Threads of recognition: Using touch as input with directionally conductive

fabric. *Proceedings of the SIGCHI conference on Human Factors in computing systems*, 2005.

Andrew Schmeder and Adrian Freed. Support vector machine learning for gestural signal estimation with a piezo-resistive fabric touch surface. In *Proceedings of the 2010 Conference on New Interfaces for Musical Expression (NIME 2010), Sydney, Australia*, pages 244–249, 2010.

M. Sergio, N. Manaresi, M. Tartagni, R. Guerrieri, and R. Canegallo. A textile based capacitive pressure sensor. In *Sensors, 2002. Proceedings of IEEE*, volume 2, pages 1625–1630 vol.2, 2002. doi: 10.1109/ICSENS.2002.1037367.

Stan S. Swallow and Asha Peta Thompson. Sensory fabric for ubiquitous interfaces. *International Journal of Human-Computer Interaction*, 13(2):147–159, 2001. doi: 10.1207/S15327590IJHC1302_4. URL http://www.tandfonline.com/doi/abs/10.1207/S15327590IJHC1302_4.

B. Thomas, K. Grimmer, J. Zucco, and S. Milanese. Where does the mouse go? an investigation into the placement of a body-attached touchpad mouse for wearable computers. *Personal Ubiquitous Comput.*, 6(2):97–112, January 2002. ISSN 1617-4909. doi: 10.1007/s007790200009. URL <http://dx.doi.org/10.1007/s007790200009>.

Malte Weiss, Simon Voelker, Christine Sutter, and Jan Borchers. Benddesk: Dragging across the curve. In *ITS '10: Proceedings of the ACM International Conference on Interactive Tabletops and Surfaces*, pages 1–10, New York, NY, USA, November 2010. ACM. ISBN 978-1-4503-0399-6.

Jacob O. Wobbrock, Andrew D. Wilson, and Yang Li. Gestures without libraries, toolkits or training: a \$1 recognizer for user interface prototypes. In *Proceedings of the 20th annual ACM symposium on User interface software and technology, UIST '07*, pages 159–168, New York, NY, USA, 2007. ACM. ISBN 978-1-59593-679-0. doi: 10.1145/1294211.1294238. URL <http://doi.acm.org/10.1145/1294211.1294238>.

Shengdong Zhao, Pierre Dragicevic, Mark Chignell, Ravin Balakrishnan, and Patrick Baudisch. Earpod: eyes-free menu selection using touch input and reactive audio

feedback. In *Proceedings of the SIGCHI conference on Human factors in computing systems, CHI '07*, pages 1395–1404, New York, NY, USA, 2007. ACM. ISBN 978-1-59593-593-9. doi: 10.1145/1240624.1240836. URL <http://doi.acm.org/10.1145/1240624.1240836>.

Index

Algorithm for gestures.....	51–52
Algorithm for gestures optimization.....	83–85
Algorithm for measuring.....	35–37
Amohr conductive tape.....	21
Analog-to-digital conversion.....	34
Arduino Duemilanove.....	21
BendDesk.....	90
Cross interaction.....	64
Design space of input devices.....	33–34
Dynamic wearability.....	16
evaluation.....	55–86
Eyes-free interaction.....	16
future work.....	89–91
GestiPants.....	3, 48–50
Gesture articulation on garments.....	9–10
Gesture set.....	42
Gropable.....	17
Guidelines.....	20
Hannah Perner-Wilson.....	25
MedTex180.....	21
Menu.....	41
Piezo-resistive foil.....	21
Requirements.....	16
Resolution.....	30–31
Sensor architecture.....	32
Smart clothing.....	1
Target.....	60
Textile screen.....	91
TextiPad.....	3, 45–47
Wack-a-mole.....	40

